

MOBILIER
FURNITURE

LITHO

LINE

Ed.5

Guillaume Delvigne for Pierre Frey



Collection ICÔNE



© Baptiste Heller

LITHO by Guillaume Delvigne

Designer diplômé en 2002 de l'École de Design Nantes Atlantique, Guillaume Delvigne débute entre Milan et Paris, auprès de grands noms comme George Sowden, cofondateur du mouvement Memphis, ou Marc Newson, star du design contemporain.

En 2011 il se lance en solo, inaugure sa première exposition personnelle à la ToolsGalerie et remporte le Grand Prix de la Création de la Ville de Paris. Aujourd'hui, il travaille avec des artisans, des éditeurs ou industriels, principalement dans le domaine du mobilier, de l'objet, et du luminaire. Il compte de nombreuses références, grandes Maisons françaises et étrangères ou jeunes éditeurs (Hermès, Frandsen, Hanoia, Lexon, La Chance, ENO studio, Hartô...).

Guillaume Delvigne est un dessinateur. Son travail, d'une grande sensibilité, est influencé par la photo, l'architecture et plus généralement, par tout ce qui est visuel. Il recherche l'équilibre parfait, sa patte est douce et épurée tout en étant extrêmement rigoureuse, son sens du détail très marqué.

A designer who graduated in 2002 from the Nantes Atlantique School of Design, Guillaume Delvigne began his career between Milan and Paris, working with big names such as George Sowden, co-founder of the Memphis movement, and Marc Newson, a star of contemporary design.

In 2011 he launches a solo show, inaugurates his first solo exhibition at the ToolsGalerie and wins the Grand Prix de la Création de la Ville de Paris. Today he works with craftsmens, publishers or industrialists mainly in the fields of furniture, objects and lighting. His clients are major French and foreign companies or younger publishers (Hermès, Frandsen, Hanoia, Lexon, La Chance, ENO studio, Hartô...).

Guillaume Delvigne is an illustrator. His highly sensitive work is influenced by photography, architecture and more generally by everything visual. He is looking for the perfect balance, his paw is soft and uncluttered while being extremely rigorous, his sense of detail is very strong.

LE CONCEPT

La ligne LITHO dessinée par Guillaume Delvigne, signifie « pierre » en grec ancien. Elle s'apparente à un paysage primitif où chaque pièce aurait sa propre personnalité et entrerait en résonance les unes avec les autres. Chaque pièce est le fruit d'un assemblage de volumes, imbriqués ou simplement posés les uns sur les autres renforçant ainsi cette présence monolithique. De grandes formes massives et sculptées à l'aspect poli presque minéral émergent. Intégralement gainées de tissu, elles rendent hommage au savoir-faire historique de la Maison.

Canapés banquettes, chauffeuse, fauteuil, bridge, tabouret, banc et poufs incitent à une attitude décontractée et conviviale. Trois tapis aux formes ondulantes habillés de virgules colorées en relief, complètent la collection. Ils créent un lien onirique et poétique entre toutes les pièces et confère à l'ensemble une notion d'espace habité.



THE CONCEPT

The LITHO line, designed by Guillaume Delvigne, means « stone » in ancient Greek. It resembles a primitive landscape where each piece would have its own personality and would resonate with each other. Each piece is the result of an assembly of volumes, either nested or simply placed one on top of the other, reinforcing this monolithic presence. Large, massive and sculpted forms emerge with a polished, almost mineral appearance. Entirely upholstered in fabric, they pay homage to the Maison's historical know-how.

Slipper chair, armless sofas, armchair, dining chair, low stool, benches and pouf evoke a relaxed and friendly attitude. Three carpets with undulating shapes dressed with colored commas in relief, complete the collection. They create a dreamlike and poetic link between all the pieces and confer to the whole a notion of inhabited space.

LITHO

LINE



LITHO
Canapé - Sofa
FLITHCA200
FLITHCA240



LITHO
Canapé banquette - Armless sofa
FLITHCB200 - FLITHCB220
FLITHCB240 - FLITHCB275



LITHO
Fauteuil - Armchair
FLITHFA086



LITHO
Canapé banquette 2 - Armless sofa 2
FLIT2CB120



LITHO
Mérienne - Chaise Lounge
FLITHME180H
FLITHME180D



LITHO
Pouf - Pouf
FLITHPO085

LITHO

LINE



LITHO
Fauteuil - Armchair
FLITHBR080



LITHO
Banc - Bench
FLITHBA150D
FLITHBA150H



LITHO
Chauffeuse - Slipper chair
FLITHCF060



LITHO
Canapé banquette 3 - Armless sofa 3
FLIT3CB120



LITHO
Tabouret - Low stool
FLITHTT060



LITHO
Banc 2 - Bench 2
FLIT2BA100

LITHO

NOVELTIES



LITHO
Chaise - Chair
FLITHCH044



LITHO
Fauteuil de table - Dining chair
FLITHBR063





































LITHO

by Guillaume Delvigne



Tissu / Fabric : TEDDY MOHAIR Moutarde F2500015

FAUTEUIL DE TABLE - DINING CHAIR

REF: FLITHBR063

STRUCTURE	FRAME
Carcasse en mousse injectée	Injected foam frame
FINITIONS PIÈTEMENT	WOOD FINISHES
Entièrement tapissé	Fully upholstered
FINITIONS TAPISSIER	UPHOLSTERED FINISHES
Tissu tendu et coutures simples	Stretched fabric and simple seams
SPÉCIFICITÉ	SPECIFICITY
Se référer à la liste de tissus compatibles	Refer to suitable fabrics list
MÉTRAGE TISSU	FABRIC QUANTITY
2,5 m	3 yds
Métrage pour un tissu uni laize 140 cm	Quantity for a plain fabric in 55" width

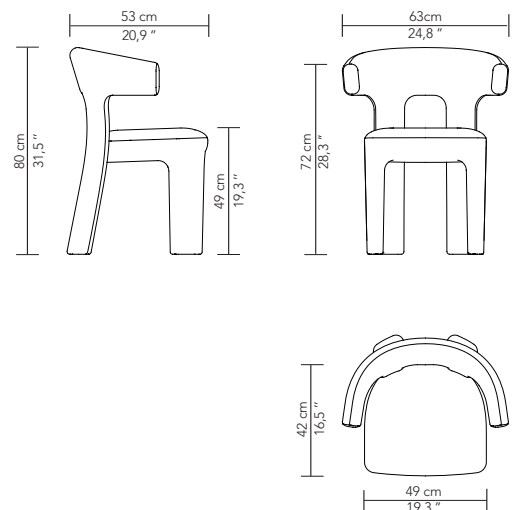





LITHO

by Guillaume Delvigne



Tissu / Fabric : OPIO Terracotta I6616006

CHAISE - CHAIR

REF: FLITHCH044

STRUCTURE	FRAME
Carcasse en mousse injectée	Injected foam frame
FINITIONS PIÈTEMENT	WOOD FINISHES
Entièrement tapissé	Fully upholstered
FINITIONS TAPISSIER	UPHOLSTERED FINISHES
Tissu tendu et coutures simples Passepoil sur le dossier	Stretched fabric and simple seams Piping on the backrest
SPÉCIFICITÉ	SPECIFICITY
Se référer à la liste de tissus compatibles	Refer to suitable fabrics list
MÉTRAGE TISSU	FABRIC QUANTITY
2,5 m Métrage pour un tissu uni laize 140 cm	3 yds Quantity for a plain fabric in 55" width

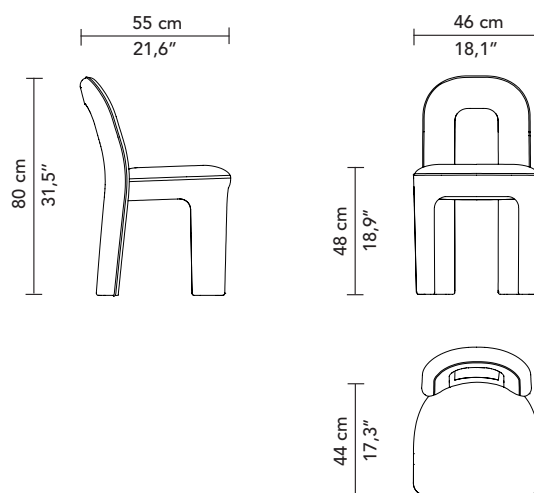

LITHO

by Guillaume Delvigne



Tissu / Fabric : PYLA Papaye F3637005

CANAPÉ - SOFA

REF: FLITHCA220

STRUCTURE	FRAME
Carcasse en hêtre	Beech
FINITIONS PIÈTEMENT	WOOD FINISHES
Entièrement tapissé	Fully upholstered
FINITIONS TAPISSIER	UPHOLSTERED FINISHES
Tissu tendu et coutures simples	Stretched fabric and simple seams
Passepoil sur le dossier et l'assise	Piping on the backrest and on the seat
SPÉCIFICITÉ	SPECIFICITY
Se référer à la liste de tissus compatibles	Refer to suitable fabrics list
MÉTRAGE TISSU	FABRIC QUANTITY
10 m	11 yds
Métrage pour un tissu uni laize 140 cm	Quantity for a plain fabric in 55" width

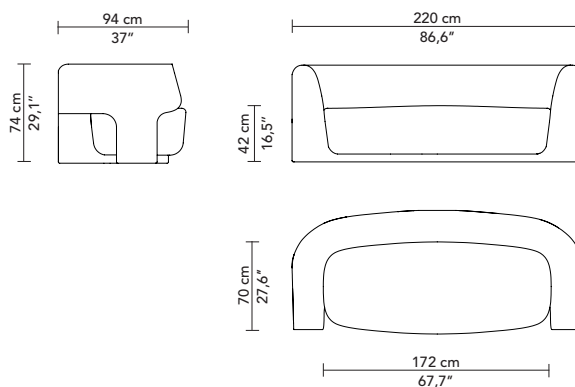





LITHO

by Guillaume Delvigne



Tissu / Fabric : PYLA Pavot F3637006

CANAPÉ - SOFA

REF: FLITHCA240

STRUCTURE	FRAME
Carcasse en hêtre	Beech
FINITIONS PIÈTEMENT	WOOD FINISHES
Entièrement tapissé	Fully upholstered
FINITIONS TAPISSIER	UPHOLSTERED FINISHES
Tissu tendu et coutures simples	Stretched fabric and simple seams
Passepoil sur le dossier et l'assise	Piping on the backrest and on the seat
SPÉCIFICITÉ	SPECIFICITY
Se référer à la liste de tissus compatibles	Refer to suitable fabrics list
MÉTRAGE TISSU	FABRIC QUANTITY
11,5 m	13 yds
Métrage pour un tissu uni laize 140 cm	Quantity for a plain fabric in 55" width

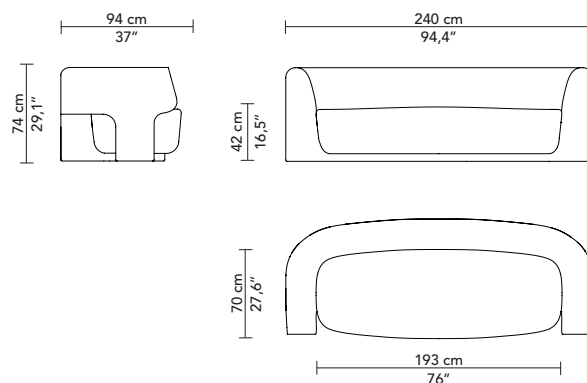

LITHO

by Guillaume Delvigne



Tissu / Fabric : ESTEBAN Tomette F3071015

CANAPÉ BANQUETTE - ARMLESS SOFA

REF: FLITHCB240

STRUCTURE	FRAME
Carcasse en hêtre	Beech
FINITIONS PIÈTEMENT	WOOD FINISHES
Entièrement tapissé	Fully upholstered
FINITIONS TAPISSIER	UPHOLSTERED FINISHES
Tissu tendu et coutures simples	Stretched fabric and simple seams
Passepoil sur le dossier et l'assise	Piping on the backrest and on the seat
SPÉCIFICITÉ	SPECIFICITY
Se référer à la liste de tissus compatibles	Refer to suitable fabrics list
MÉTRAGE TISSU	FABRIC QUANTITY
9,5 m	10,5 yds
Métrage pour un tissu uni laize 140 cm	Quantity for a plain fabric in 55" width

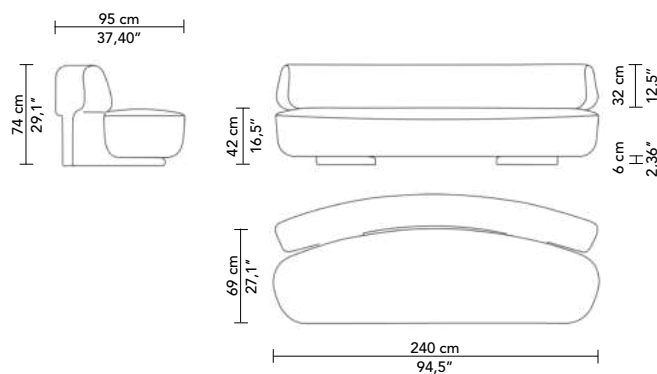





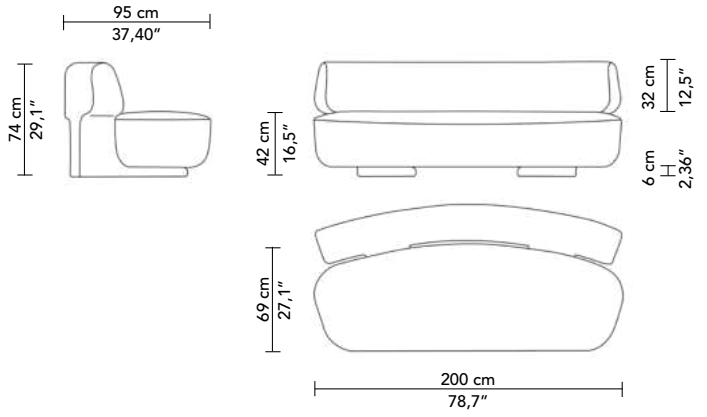

REF: FLITHCB200 - LITHO

Métrage pour un tissu uni en laize 140 cm : 8,5 m
 Quantity for a plain fabric 55" width: 9,5 yds

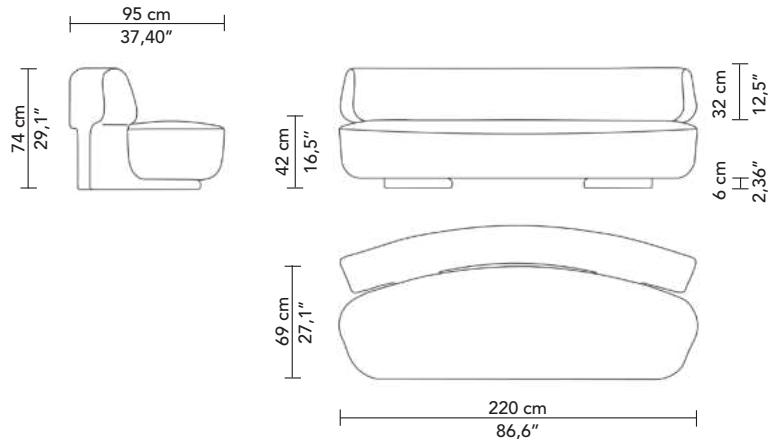

REF: FLITHCB220 - LITHO

Métrage pour un tissu uni en laize 140 cm : 9 m
 Quantity for a plain fabric 55" width: 10 yds

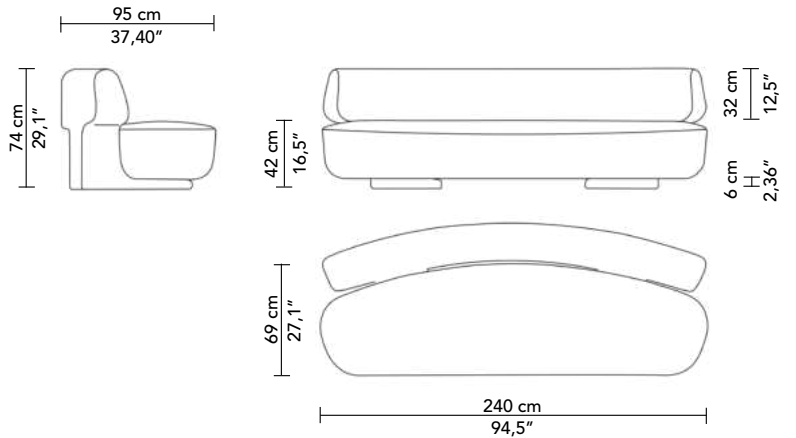

REF: FLITHCB240 - LITHO

Métrage pour un tissu uni en laize 140 cm : 9,5 m
 Quantity for a plain fabric 55" width: 10,5 yds

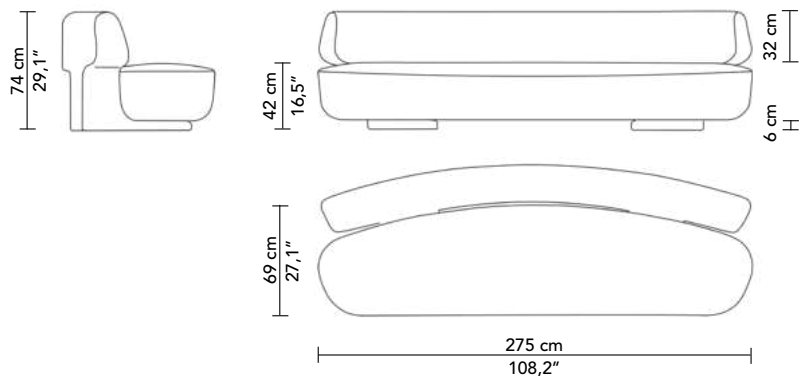

REF: FLITHCB275 - LITHO

Métrage pour un tissu uni en laize 140 cm : 10,5 m
 Quantity for a plain fabric 55" width: 11,5 yds

LITHO

by Guillaume Delvigne



Tissu / Fabric : OPIO Prussiana I6616010

CANAPÉ BANQUETTE - ARMLESS SOFA

REF: FLIT2CB120

STRUCTURE	FRAME
Carcasse en hêtre	Beech
FINITIONS PIÈTEMENT	WOOD FINISHES
Entièrement tapissé	Fully upholstered
FINITIONS TAPISSIER	UPHOLSTERED FINISHES
Tissu tendu et coutures simples Passepoil sur le dossier et l'assise	Stretched fabric and simple seams Piping on the backrest and on the seat
SPÉCIFICITÉ	SPECIFICITY
Se référer à la liste de tissus compatibles	Refer to suitable fabrics list
MÉTRAGE TISSU	FABRIC QUANTITY
5 m Métrage pour un tissu uni laize 140 cm	5,5 yds Quantity for a plain fabric in 55" width

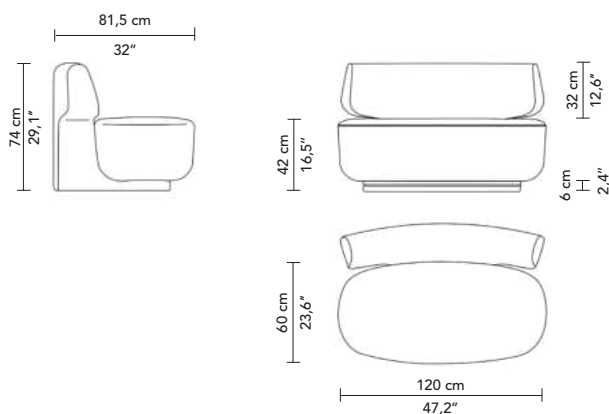





LITHO

by Guillaume Delvigne



Tissu / Fabric : PYLA Litchi F3637002

MÉRIDIENNE - DAY BED

REF: FLITHME180H

STRUCTURE	FRAME
Carcasse en hêtre	Beech
FINITIONS PIÈTEMENT	WOOD FINISHES
Entièrement tapissé	Fully upholstered
FINITIONS TAPISSIER	UPHOLSTERED FINISHES
Tissu tendu et coutures simples Passepoil sur le dossier et l'assise	Stretched fabric and simple seams Piping on the backrest and on the seat
SPÉCIFICITÉ	SPECIFICITY
Se référer à la liste de tissus compatibles Existe en version droite : FLITHME180D Existe en version gauche : FLITHME180H	Refer to suitable fabrics list Available in right version: FLITHME180D Available in left version: FLITHME180H
MÉTRAGE TISSU	FABRIC QUANTITY
- FLITHME180D : 7 m - FLITHME180H : 7 m Métrage pour un tissu uni laize 140 cm	- FLITHME180D: 7,5 yds - FLITHME180H: 7,5 yds Quantity for a plain fabric in 55" width

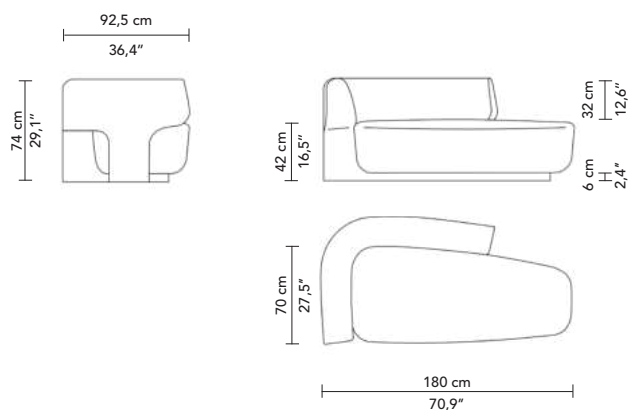

LITHO

by Guillaume Delvigne



Tissu / Fabric : PYLA Muscade F3637013

FAUTEUIL - ARMCHAIR

REF: FLITHFA086

STRUCTURE	FRAME
Carcasse en hêtre	Beech
FINITIONS PIÈTEMENT	WOOD FINISHES
Entièrement tapissé	Fully upholstered
FINITIONS TAPISSIER	UPHOLSTERED FINISHES
Tissu tendu et coutures simples Passepoil sur le dossier et l'assise	Stretched fabric and simple seams Piping on the backrest and on the seat
SPÉCIFICITÉ	SPECIFICITY
Se référer à la liste de tissus compatibles	Refer to suitable fabrics list
MÉTRAGE TISSU	FABRIC QUANTITY
4,5 m Métrage pour un tissu uni laize 140 cm	4,5 yds Quantity for a plain fabric in 55" width

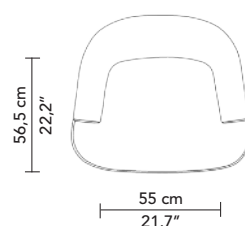
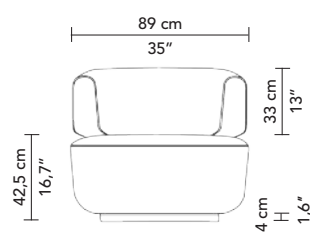
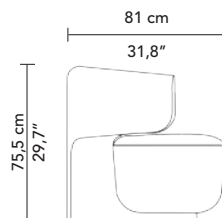





LITHO

by Guillaume Delvigne



Tissu / Fabric : CLEMENCE Naturel F3420001

CHAUFFEUSE - SLIPPER CHAIR

REF: FLITHCF060

STRUCTURE	FRAME
Carcasse en mousse injectée	Injected foam frame
FINITIONS PIÈTEMENT	WOOD FINISHES
Entièrement tapissé	Fully upholstered
FINITIONS TAPISSIER	UPHOLSTERED FINISHES
Tissu tendu et coutures simples Passepoil sur le dossier	Stretched fabric and simple seams Piping on the backrest
SPÉCIFICITÉ	SPECIFICITY
Se référer à la liste de tissus compatibles	Refer to suitable fabrics list
MÉTRAGE TISSU	FABRIC QUANTITY
2,5 m Métrage pour un tissu uni laize 140 cm	3 yds Quantity for a plain fabric in 55" width

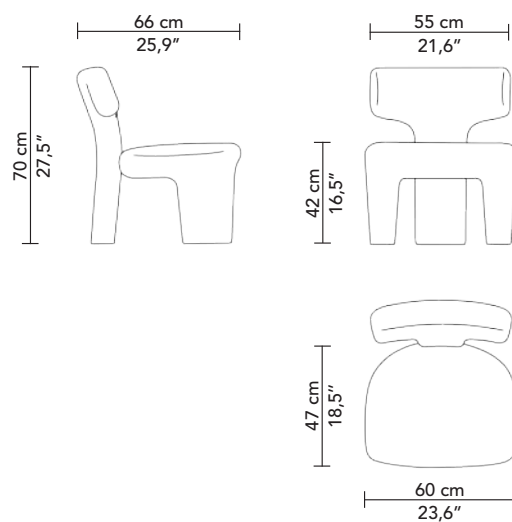

LITHO

by Guillaume Delvigne



Tissu / Fabric : GIPSY Graphite F3608019

FAUTEUIL - ARMCHAIR

REF: FLITHBR080

STRUCTURE	FRAME
Carcasse en mousse injectée	Injected foam frame
FINITIONS PIÈTEMENT	WOOD FINISHES
Entièrement tapissé	Fully upholstered
FINITIONS TAPISSIER	UPHOLSTERED FINISHES
Tissu tendu et coutures simples Passepoil sur le dossier	Stretched fabric and simple seams Piping on the backrest
SPÉCIFICITÉ	SPECIFICITY
Se référer à la liste de tissus compatibles	Refer to suitable fabrics list
MÉTRAGE TISSU	FABRIC QUANTITY
3 m Métrage pour un tissu uni laize 140 cm	3,5 yds Quantity for a plain fabric in 55" width

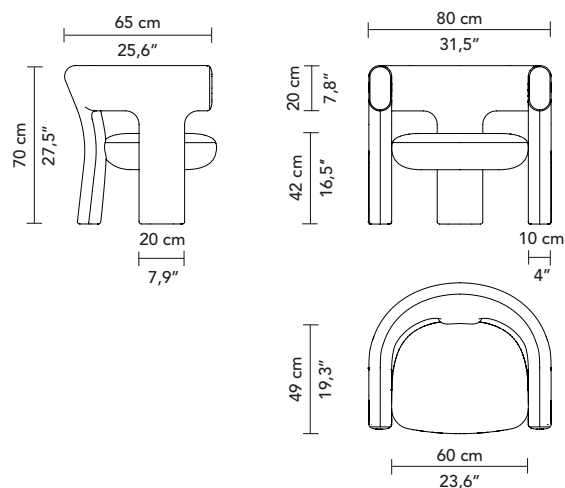





LITHO

by Guillaume Delvigne



Tissu / Fabric : SOLANGE Souris F3432002

CANAPÉ BANQUETTE - ARMLESS SOFA

REF: FLIT3CB120

STRUCTURE	FRAME
Carcasse en mousse injectée	Injected foam frame
FINITIONS PIÈTEMENT	WOOD FINISHES
Entièrement tapissé	Fully upholstered
FINITIONS TAPISSIER	UPHOLSTERED FINISHES
Tissu tendu et coutures simples Passepoil sur le dossier	Stretched fabric and simple seams Piping on the backrest
SPÉCIFICITÉ	SPECIFICITY
Se référer à la liste de tissus compatibles	Refer to suitable fabrics list
MÉTRAGE TISSU	FABRIC QUANTITY
4 m Métrage pour un tissu uni laize 140 cm	4,5 yds Quantity for a plain fabric in 55" width

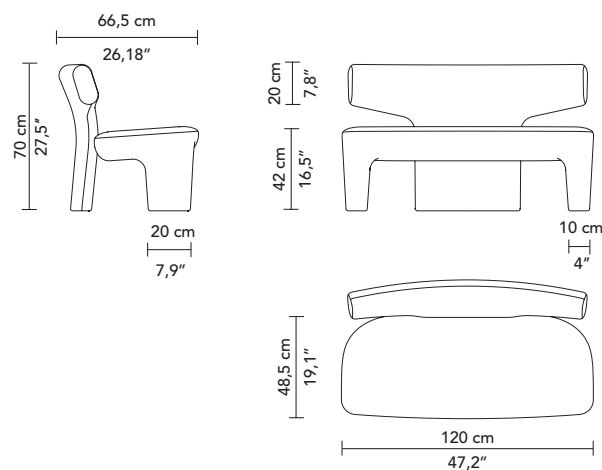

LITHO

by Guillaume Delvigne



Tissu / Fabric : BYRON (Discontinued)

BANC - BENCH

REF: FLITHBA150H

STRUCTURE	FRAME
Carcasse en hêtre	Beech
FINITIONS PIÈTEMENT	WOOD FINISHES
Entièrement tapissé	Fully upholstered
FINITIONS TAPISSIER	UPHOLSTERED FINISHES
Tissu tendu et coutures simples Passepoil sur le dossier et l'assise	Stretched fabric and simple seams Piping on the backrest and on the seat
SPÉCIFICITÉ	SPECIFICITY
Se référer à la liste de tissus compatibles Existe en version droite : FLITHBA150D Existe en version gauche : FLITHBA150H	Refer to suitable fabrics list Available in right version : FLITHBA150D Available in left version : FLITHBA150H
MÉTRAGE TISSU	FABRIC QUANTITY
- FLITHBA150D : 3 m - FLITHBA150H : 3 m Métrage pour un tissu uni laize 140 cm	- FLITHBA150D: 3,5 yds - FLITHBA150H: 3,5 yds Quantity for a plain fabric in 55" width

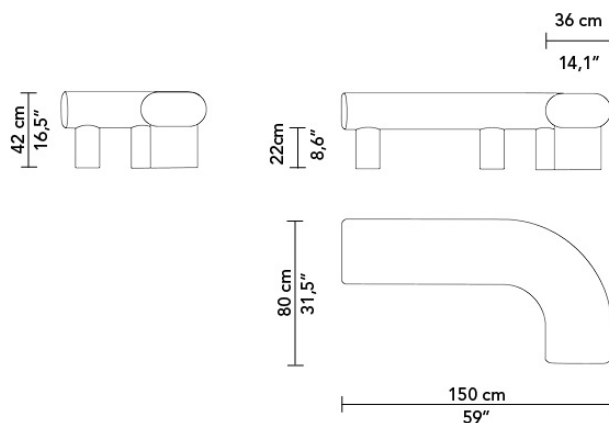





LITHO

by Guillaume Delvigne



Tissu / Fabric : MENERBES Ecrú F3445002

BANC - BENCH

REF: FLIT2BA100

STRUCTURE	FRAME
Carcasse en mousse injectée	Injected foam frame
FINITIONS PIÈTEMENT	WOOD FINISHES
Entièrement tapissé	Fully upholstered
FINITIONS TAPISSIER	UPHOLSTERED FINISHES
Tissu tendu et coutures simples	Stretched fabric and simple seams
SPÉCIFICITÉ	SPECIFICITY
Se référer à la liste de tissus compatibles	Refer to suitable fabrics list
MÉTRAGE TISSU	FABRIC QUANTITY
2,5 m Métrage pour un tissu uni laize 140 cm	3 yds Quantity for a plain fabric in 55" width

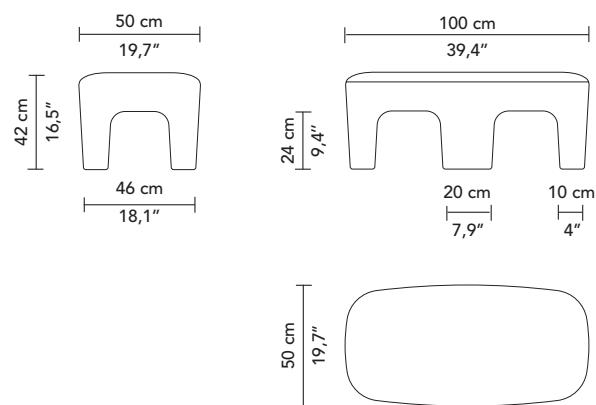

LITHO

by Guillaume Delvigne



Tissu / Fabric : YETI Olive F3290010

TABOURET - LOW STOOL

REF: FLITHTT060

STRUCTURE	FRAME
Carcasse en mousse injectée	Injected foam frame
FINITIONS PIÈTEMENT	WOOD FINISHES
Entièrement tapissé	Fully upholstered
FINITIONS TAPISSIER	UPHOLSTERED FINISHES
Tissu tendu et coutures simples	Stretched fabric and simple seams
SPÉCIFICITÉ	SPECIFICITY
Se référer à la liste de tissus compatibles	Refer to suitable fabrics list
MÉTRAGE TISSU	FABRIC QUANTITY
2 m	2 yds
Métrage pour un tissu uni laize 140 cm	Quantity for a plain fabric in 55" width

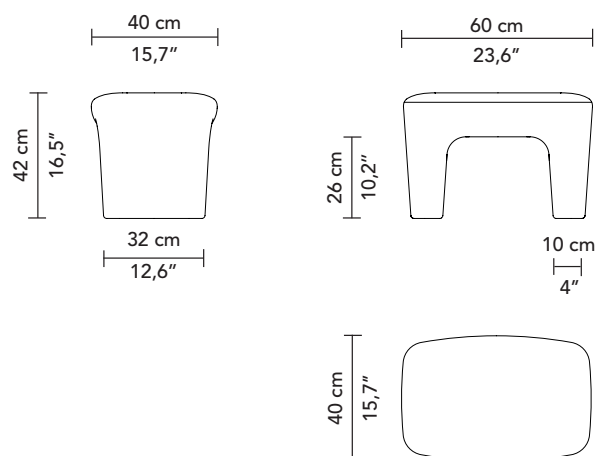





LITHO

by Guillaume Delvigne



Tissu / Fabric : CHEYENNE Flamingo F3222019

POUF

REF: FLITHPO085

STRUCTURE	FRAME
Carcasse en hêtre	Beech
FINITIONS PIÈTEMENT	WOOD FINISHES
Entièrement tapissé	Fully upholstered
FINITIONS TAPISSIER	UPHOLSTERED FINISHES
Tissu tendu et coutures simples	Stretched fabric and simple seams
Passepoil sur le dossier et l'assise	Piping on the backrest and on the seat
SPÉCIFICITÉ	SPECIFICITY
Se référer à la liste de tissus compatibles	Refer to suitable fabrics list
MÉTRAGE TISSU	FABRIC QUANTITY
3,5 m	4 yds
Métrage pour un tissu uni laize 140 cm	Quantity for a plain fabric in 55" width

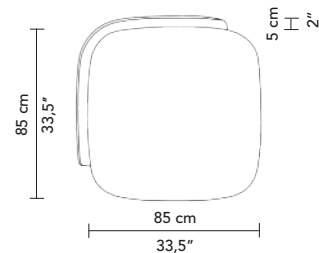
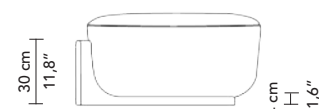
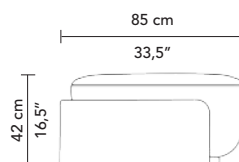







TAPIS COORDONÉS
COORDINATED RUGS

SIERRA

by Guillaume Delvigne



TAPIS - RUG

REF: FT271001

TECHNIQUE	TECHNIQUE
Tufté-main	Hand-tuft
USAGE	WOOD FINISHES
Trafic modéré	Moderate traffic
COMPOSITION	COMPOSITION
52 % Bambou, 48% Laine 380Tex	52% Bamboo, 48 % Wool 380Tex
DENSITÉ	DENSITY
H650	104 oz/y ²
VELOURS	PILE
Velours coupé overtufté et bouclé	Overtufted cut pile & loop pile
Hauteur de velours : 8mm (velours bouclé)	Pile height: 0.31" (loop pile)
10 mm (velours coupé)	0.39" (cut pile)
HAUTEUR TOTALE	TOTAL HEIGHT
13 mm	0.51"
POIDS TOTAL	TOTAL WEIGHT
6 000 g/m ²	19.66 oz/ft ²

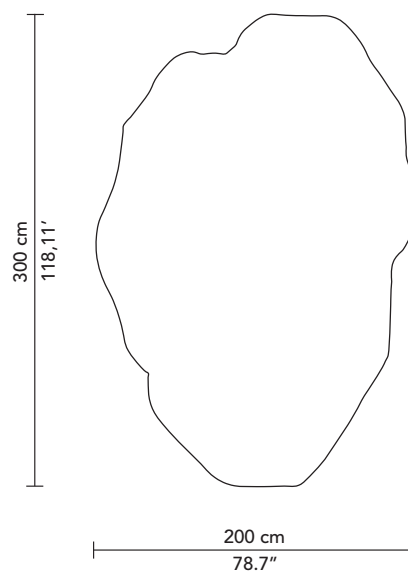

TOUNDRRA

by Guillaume Delvigne



TAPIS - RUG

REF: FT270001

TECHNIQUE	TECHNIQUE
Tufté-main	Hand-tuft
USAGE	WOOD FINISHES
Trafic modéré	Moderate traffic
COMPOSITION	COMPOSITION
51 % Laine 250Tex, 33% Laine 380 Tex, 16% Shiny nylon	51 % Wool 250Tex, 33% Wool 380 Tex, 16% Shiny nylon
DENSITÉ	DENSITY
H550	88 oz/y ²
VELOURS	PILE
Velours bouclé high and low Hauteur de velours : 6mm, 10 mm	High and low loop pile Pile height: 0.24", 0.39"
HAUTEUR TOTALE	TOTAL HEIGHT
13 mm	0.51"
POIDS TOTAL	TOTAL WEIGHT
4 400 g/m ²	14.42 oz/ft ²

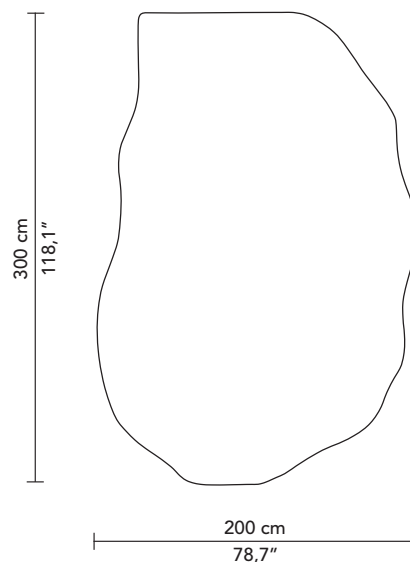

STEPPE

by Guillaume Delvigne

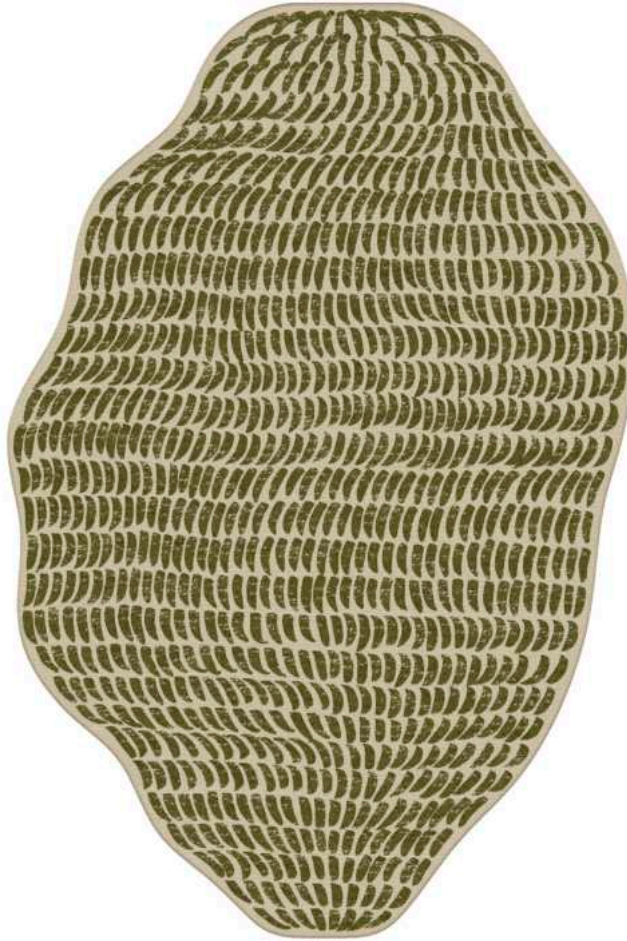

TAPIS - RUG

REF: FT269001

TECHNIQUE	TECHNIQUE
Tufté-main	Hand-tuft
USAGE	WOOD FINISHES
Trafic modéré	Moderate traffic
COMPOSITION	COMPOSITION
54% Bambou, 46 % Laine 380 Tex	54 % Bamboo, 46 % Wool 380 Tex
DENSITÉ	DENSITY
H650	104 oz/y ²
VELOURS	PILE
Velours coupé overtufté et bouclé	Overtufted cut pile & loop pile
Hauteur de velours : 8mm (velours bouclé)	Pile height: 0.31" (loop pile)
10 mm (velours coupé)	0.39" (cut pile)
HAUTEUR TOTALE	TOTAL HEIGHT
13 mm	0.51"
POIDS TOTAL	TOTAL WEIGHT
6 000 g/m ²	19.66 oz/ft ²

