



MOBILIER
FURNITURE

ALTAR

LIGNE / LINE

Daniel ROUS pour / for Pierre Frey





ALTAR

by Daniel ROUS

En 2013, le designer anglais Daniel Rous est diplômé de la Bath School of Art & Design. L'année suivante, il part à Trévise, en Italie et passe quelques années au centre de recherche d'art Fabrica. Il intègre dans un premier temps cette institution en tant que designer résident puis il devient consultant.

En 2017, il revient à Londres et décide de se spécialiser dans la conception d'objet. Il travaille à la fois comme designer et consultant pour des marques et des studios tels que Bethan Laura Wood, Established & Sons, Faye Toogood, DesignStudio et Pentagram.

Son travail brouille les pistes entre artisanat et design industriel. Doté d'une véritable curiosité et portant un regard précis sur les techniques et les savoir-faire, Daniel Rous révèle et met en valeur les capacités et spécificités des artisans. Il puise son inspiration dans le mobilier monolithique et monumental que l'on trouve au centre des églises anciennes.

In 2013, English designer Daniel Rous graduated from the Bath School of Art & Design. The following year, he moved to Treviso, Italy and spent a few years at the Fabrica art research center. He first joined this institution as a resident designer and then became a consultant.

In 2017, he returned to London and decided to specialize in object design. He works both as a designer and consultant for brands and studios such as Bethan Laura Wood, Established & Sons, Faye Toogood, DesignStudio and Pentagram.

His work blurs the line between craftsmanship and industrial design. Endowed with a genuine curiosity and a precise look at techniques and know-how, Daniel Rous reveals and highlights the capacities and specificities of the artisans. He draws his inspiration from the monolithic and monumental furniture found in the center of ancient churches.

LE CONCEPT

La collection Altar dessinée par Daniel Rous est inspirée du mobilier monolithique et monumental des églises anciennes. Son esthétique imposante de bloc aux proportions généreuses rappelle leurs autels, pièces maitresses et centrales autour desquelles se rassemblent les communautés de façon rituelle et conviviale. La lumière accroche et souligne avec élégance, l'impressionnant travail de découpe des multiples facettes. Comme une sculpture taillée dans la masse, ALTAR rend hommage au travail et savoir-faire des ébénistes de la Maison Pierre Frey.

La fabrication en bois massif renforce l'esthétique monolithique des pièces. Une finition élégante et sophistiquée souligne la subtilité de la matière, le veinage du frêne ou du chêne.

THE CONCEPT

The Altar collection designed by Daniel Rous is inspired by the monolithic and monumental furniture of ancient churches. Its imposing, generously proportioned block aesthetic is reminiscent of the altar, the centerpiece of a church around which communities gather, as a ritual or to be convivial. The light catches and underlines with elegance the impressive work of cutting the multiple facets. Like a sculpture carved out of the mass, ALTAR pays tribute to the work and know-how of Maison Pierre Frey's carpenters.

The solid wood fabrication reinforces the monolithic aesthetics of the pieces. An elegant and sophisticated finish underlines the subtlety of the material, the veining of ash or oak.

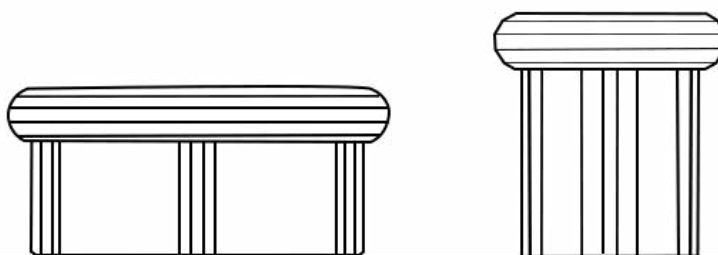

LA COLLECTION



ALTAR
Guéridon / Pedestal table
FALTAGU050



ALTAR
Table / Coffee table
FALTATA090















ALTAR Daniel Rous pour / for Pierre Frey

GUÉRIDON / PEDESTAL TABLE

REF: FALTAGU050

STRUCTURE	FRAME
Structure : Chêne massif	Structure : Solid oak
Assemblage : traditionnel	Construction : traditional
PIETEMENT	LEG FINISHES
Chêne blanchi	Bleached oak
PIÈCES COORDONNÉES	COORDINATED PIECES
Table	Table

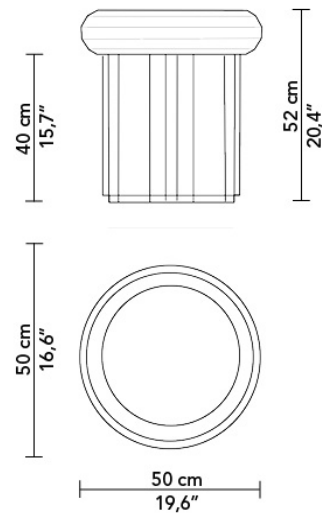

COLIS : 1

Volume brut : 0,17 m3
 Poids brut : 20 kg
 Dimensions brutes : L 56 x P 56 x H 56 cm
 Eco participation obligatoire pour une livraison en France : 2,4€

PARCEL: 1

Gross volume : 6 ft3
 Gross weight : 44 lbs
 Gross dimensions : L 22"x D 22"x H 22"

FICHE TECHNIQUE / TECHNICAL SHEET



ALTAR Daniel Rous pour / for Pierre Frey

TABLE BASSE / COFFEE TABLE

REF: FALTATA090

STRUCTURE	FRAME
Structure : Frêne massif & plateau en verre Assemblage : traditionnel	Structure : Solid ash & glass tray Construction : traditional
PIETEMENT	LEG FINISHES
Frêne blanchi cérusé	Waxed bleached ash
SPÉCIFICITÉ	SPECIFICITY
Papier peint personnalisable sous le plateau en verre	Customizable wallpaper under the glass tray
PIÈCES COORDONNÉES	COORDINATED PIECES
Guéridon	Pedestal table

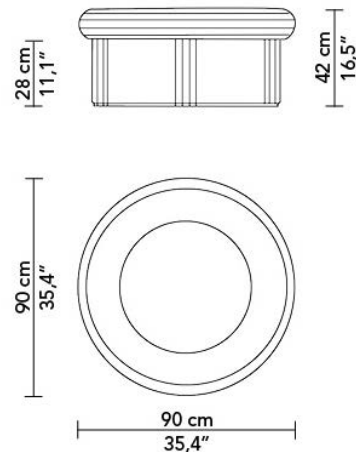

COLIS : 1

Volume brut : 0,41 m3
Poids brut : 44 kg
Dimensions brutes : L 96 x P 96 x H 45 cm
Eco participation obligatoire pour une livraison en France : 5,28 €

PARCEL: 1

Gross volume : 14,47 ft3
Gross weight : 97 lbs
Gross dimensions : L 37,8" x D 37,8" x H 17,7"