



MOBILIER
FURNITURE

LAPEL

LIGNE - LINE

Gonçalo Campos for Pierre Frey





L A P E L by Gonçalo Campos

Gonçalo Campos est un jeune designer portugais reconnu pour son mélange d'humour et de pragmatisme. En 2008, il rejoint Fabrica, centre de recherche en design et communication à Trévise. Dès 2010, il collabore avec différents éditeurs comme Wewood, Mantecas, Vista Alegre ou Kvadrat...

Très curieux par nature, il aime comprendre la fabrication des choses et l'ingéniosité des personnes derrière chaque projet. Son travail tend à trouver des solutions simples mais surprenantes par l'utilisation rationnelle des matériaux et des méthodes de production.

Gonçalo Campos is a young Portuguese designer known for his mix of humor and pragmatism. In 2008, he joined Fabrica, a design and communication research center in Treviso. Since 2010, he collaborates with different editors like Wewood, Mantecas, Vista Alegre or Kvadrat...

Very curious by nature, he likes to understand how things are made and the ingenuity of the people behind each project. His work tends to find simple but surprising solutions through the rational use of materials and production methods.

LE CONCEPT

Gonçalo Campos puise son inspiration dans le monde de la mode pour dessiner la ligne LAPEL. LAPEL évoque en anglais le revers du col d'une veste de costume. Réalisé à l'image d'un tailleur ajusté. On retrouve cette ligne graphique sur l'accotoir. L'assise repose avec légèreté sur un piètement sophistiqué en chêne massif. Les pièces présentent une esthétique appréciable sous tous les angles. Le passepoil souligne les contours, les volumes et la finesse d'exécution de l'ensemble.

THE CONCEPT

Gonçalo Campos draws his inspiration from the fashion world to design the LAPEL line. This model evokes the lapel of a suit jacket, made in the image of a fitted suit. We can find this graphic line on the armrest. The seat lays lightly on a sophisticated solid oak base. The pieces are aesthetically pleasing from all angles. The piping emphasizes the contours, the volumes and the finesse as a whole piece.

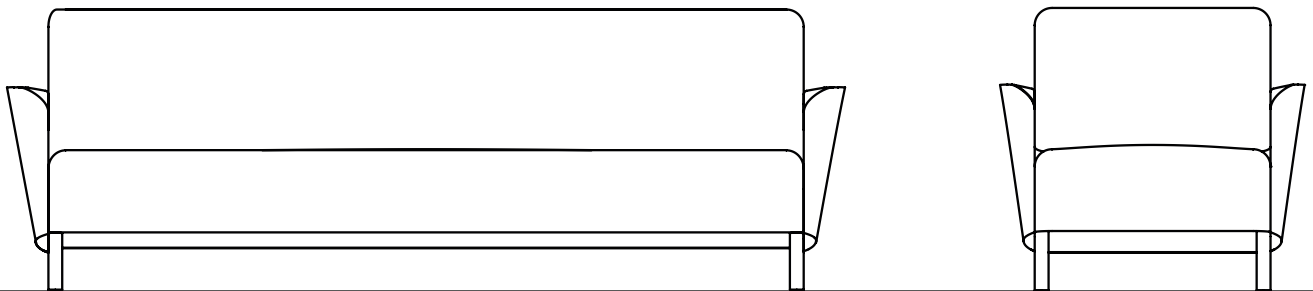

LAPEL LIGNE - LINE



LAPEL
Fauteuil - Armchair
FLAPEFA090



LAPEL
Canapé - Sofa
FLAPECA244







































FICHE TECHNIQUE / TECHNICAL SHEET



Tissu / Fabric : PIEDS DE COQ_L4432_14_3016

LAPEL

FAUTEUIL - ARMCHAIR

REF: FLAPEFA090

STRUCTURE	FRAME
Chêne massif et hêtre massif Assemblage : Traditionnel	Solid oak and solid beech Construction : traditional
CONFORT	COMFORT
Sangles élastiques Structure : Mousse CMHR4348 Assise : Mousse CMHD55, CMHR2818 et CMHR4338, parmentée de ouate polyester Dossier : Mousse CMHR2818 parmentée de ouate polyester	Elastic webbing Structure : CMHR4348 foam Assise : CMHD55, CMHR2818 and CMHR4338 foam, wrapped in polyester wadding Backrest : CMHR2818, wrapped in polyester wadding
PIETEMENT	LEG FINISHES
Chêne massif teinté, vernis à l'eau	Solid oak stained, water based varnish
FINITIONS TAPISSIER	UPHOLSTERED FINISHES
Tissu tendu et passepoil	Stretched fabric and piping
OPTION	OPTION
Coussin cale-reins déhoussable (70% plumes d'oies et 30% ouate de polyester) FLAPEFACU2	Removable lumbar cushion (70% goose feathers and 30% polyester wadding) FLAPEFACU2
PIÈCES COORDONNÉES	COORDINATED PIECES
Canapé	Sofa

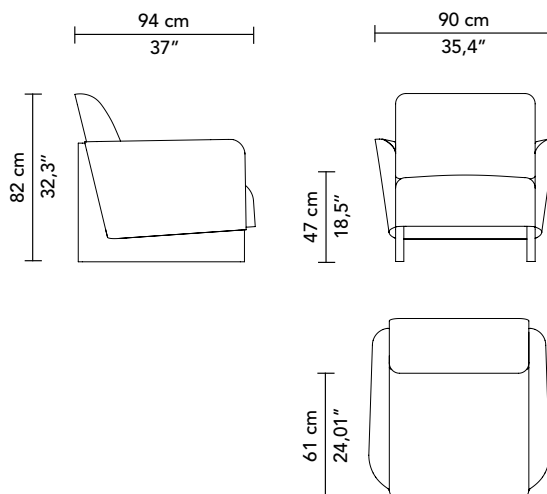

MÉTRAGE TISSU

- FLAPEFA090 : 5 m
- FLAPEFACU2 : 1 m

FABRIC QUANTITY

- FLAPEFA090 : 5,5 yds
- FLAPEFACU2 : 1 yds

Poids : 40 kg

Weight : 88,2 lbs

Eco participation obligatoire pour une livraison en France : 4,8 € HT



FICHE TECHNIQUE / TECHNICAL SHEET



Tissu / Fabric : HOGGAR L3845_3161_E

LAPEL

CANAPE - SOFA

REF: FLAPECA244

STRUCTURE	FRAME
Chêne massif et hêtre massif Assemblage : Traditionnel	Solid oak and solid beech Construction : traditional
CONFORT	COMFORT
Sangles élastiques Structure : Mousse CMHR4348 Assise : Mousse CMHD55, CMHR2818 et CMHR4338, parmentée de ouate polyester Dossier : Mousse CMHR2818 parmentée de ouate polyester	Elastic webbing Structure : CMHR4348 foam Assise : CMHD55, CMHR2818 and CMHR4338 foam, wrapped in polyester wadding Backrest : CMHR2818, wrapped in polyester wadding
PIETEMENT	LEG FINISHES
Chêne massif teinté, vernis à l'eau	Solid oak stained, water based varnish
FINITIONS TAPISSIER	UPHOLSTERED FINISHES
Tissu tendu et passepoil	Stretched fabric and piping
OPTION	OPTION
Coussins cale-reins déhoussables (70% plumes d'oies et 30% ouate de polyester) FLAPECACU1	Removable lumbar cushions (70% goose feathers and 30% polyester wadding), FLAPECACU1
PIÈCES COORDONNÉES	COORDINATED PIECES
Fauteuil	Armchair

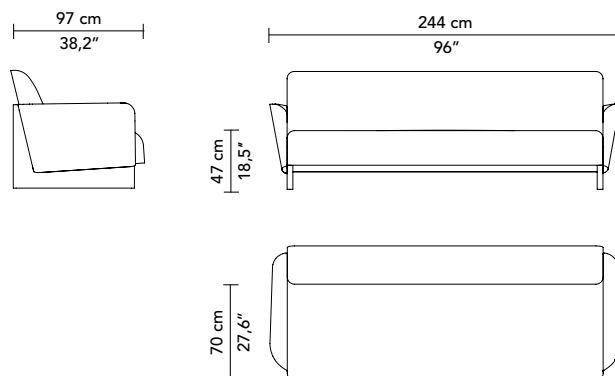

MÉTRAGE TISSU

- FLAPECA244 : 8,5 m
- FLAPECACU1 : 3 m

FABRIC QUANTITY

- FLAPEFA090 : 9,5 yds
- FLAPECACU1 : 3 yds

Poids : 80 kg

Weight : 176,4 lbs

Eco participation obligatoire pour une livraison en France : 9,6 € HT

