



MOBILIER
FURNITURE

FRAME

LIGNE - LINE

Gesa HANSEN pour / for Pierre Frey





FRAME

by Gesa HANSEN

Gesa Hansen est une designer germano-danoise. Elle grandit en Allemagne entourée d'architectes, ébénistes et designers et suit des études de design à l'Université Bauhaus de Weimar.

Elle travaille au studio de Jean Nouvel, puis dans l'atelier graphique H5 et enfin chez NDC à Tokyo avant de fonder sa propre marque « The Hansen Family ». Au sein de ce label, elle combine son expertise en design avec celui des savoir-faire de son atelier familial.

Elle développe un style au caractère artisanal fort avec pour matière de prédilection : le bois. Elle remporte deux fois le prix international Red Dot et le prix international Good Design Award du Chicago Athenaeum. S'intéressant à l'aménagement des espaces dans leur intégralité, Gesa Hansen fonde également une agence de décoration d'intérieur avec Pascaline Futry, puis en solo.

Gesa Hansen is a Danish-German designer. She grew up in Germany surrounded by architects, cabinetmakers and designers and studied design at the Bauhaus University in Weimar.

She worked at Jean Nouvel's studio, then at the graphic design studio H5 and finally at NDC in Tokyo before founding her own brand «The Hansen Family». In this label, she combines her design expertise with the know-how of her family workshop.

She develops a style with a strong artisanal character with wood as her favorite material. She has twice won the International Red Dot Award and the International Good Design Award from the Chicago Athenaeum. Interested in the design of spaces in their entirety, Gesa Hansen also founded an interior design agency with Pascaline Futry, then on her own.

LE CONCEPT

La ligne FRAME revisite avec sophistication la traditionnelle banquette française dans un esprit minimaliste et organique. Le piètement et le châssis fusionnent pour donner l'illusion d'une pièce construite d'un seul tenant, comme si elle avait été taillée dans un bloc de bois unique. Le haut du piètement dépasse de quelques centimètres, à la manière d'un dé de raccordement, pour créer une liaison élégante entre le cadre et le piètement. La simplicité de la forme valorise la beauté du veinage du bois.

THE CONCEPT

The FRAME line revisits with sophistication the traditional French bench in a minimalist and organic spirit. The base and the frame merge to give the illusion of a piece built in one piece, as if it had been carved from a single block of wood. The top of the base protrudes a few inches, like a connecting die, to create an elegant connection between the frame and the base. The simplicity of the form enhances the beauty of the wood grain.

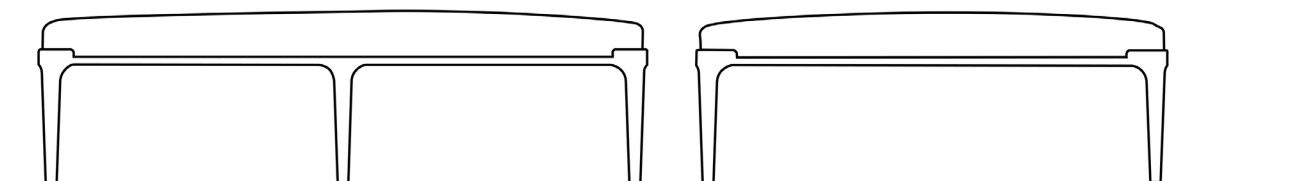

FRAME LIGNE / LINE

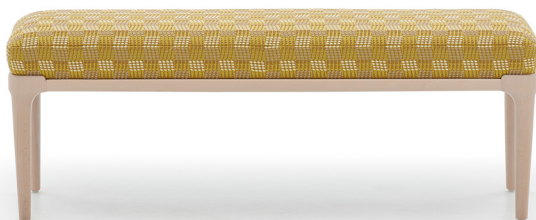

FRAME
Banc / Bench
FFRAMBA125



FRAME
Banc / Bench
FFRAMBA160



FRAME
Canapé banquette / Armless sofa
FFRAMCB125























FICHE TECHNIQUE / TECHNICAL SHEET



Tissu / Fabric : Dossier - Back : CROZON Ecru F3404001
Assise - Seat : BALTAZAR Ocre F3370026

FRAME Gesa Hansen pour / for Pierre Frey

CANAPE / CANAPE BANQUETTE

REF: FFRAMCB125

STRUCTURE	FRAME
Hêtre massif et panneau de bois Assemblage : Traditionnel	Solid beech and wood panel Construction: Traditional
CONFORT	COMFORT
Châssis plein Mousse HR (Haute Résilience) 40kg/m3 Assise : Mousse haute résilience 2 densités: 45 kg/m3 et 26 kg/m3 parementée de ouate polyester Dossier : Mousse HR 26kg/m3, parementée de ouate polyester	Solid wood seat HR foam (High Resilience) 40kg/m3 Seat : High resilience foam 2 densities: 45 kg/m3 and 26 kg/m3 wrapped in polyester wadding Back : HR foam 26kg/m3, wrapped in polyester wadding
PIETEMENT	LEG FINISHES
Intégré à la structure - Hêtre teinté vernis à l'eau	Water-based stained varnished beech
FINITIONS TAPISSIER	UPHOLSTERED FINISHES
Tissu tendu, couture simple et passepoil	Stretched fabric, single needle stitching and piping

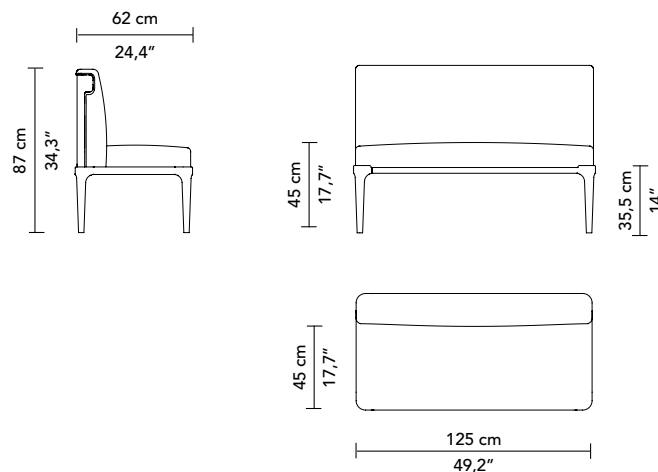

MÉTRAGE TISSU	FABRIC QUANTITY
- FFRAMCB125 : 3 m	- FFRAMCB125 : 3,3 yds

Poids : 31 kg
Eco participation obligatoire pour une livraison
en France : 3,72 € HT

Weight : 68,4 lbs



FICHE TECHNIQUE / TECHNICAL SHEET



Tissu / Fabric : OTTI Ambre F3518001

FRAME Gesa Hansen pour / for Pierre Frey

BANC / BENCH

REF: FFRAMBA125

STRUCTURE	FRAME
Hêtre massif	Solid beech
Assemblage : Traditionnel	Construction: Traditional
CONFORT	COMFORT
Châssis plein	Solid wood seat
Assise : Mousse haute résilience 2 densités: 45 kg/m3 et 25 kg/m3 parementée de ouate polyester	Seat : High resilience foam 2 densities 45 and 25 kg/m3 wrapped in polyester wadding
PIETEMENT	LEG FINISHES
Intégré à la structure - Hêtre teinté vernis à l'eau	Water-based stained varnished beech
FINITIONS TAPISSIER	UPHOLSTERED FINISHES
Tissu tendu, couture simple	Stretched fabric and single needle stitching
SPÉCIFICITÉ	SPECIFICITY
Existe en 160cm de longueur FFRAMBA160	Available in 66,5" length FFRAMBA160

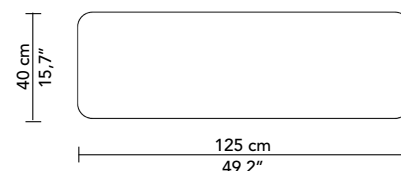
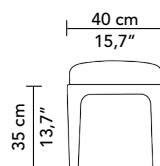

MÉTRAGE TISSU	FABRIC QUANTITY
- FFRAMBA125 : 1 m	- FFRAMBA125 : 1,1 yds
- FFRAMBA160 : 1,8 m	- FRAMBA160 : 2 yds

Poids : 10 kg

Weight : 22 lbs

Eco participation obligatoire pour une livraison en France : 1,2€ HT



FICHE TECHNIQUE / TECHNICAL SHEET



Tissu / Fabric : OTTI Ambre F3518001

FRAME Gesa Hansen pour / for Pierre Frey

BANC / BENCH

REF: FFRAMBA160

STRUCTURE	FRAME
Hêtre massif Assemblage : Traditionnel	Solid beech Construction: Traditional
CONFORT	COMFORT
Châssis plein Assise : Mousse haute résilience 2 densités: 45 kg/m3 et 25 kg/m3 parementée de ouate polyester	Solid wood seat Seat : High resilience foam 2 densities 45 and 25 kg/m3 wrapped in polyester wadding
PIETEMENT	LEG FINISHES
Intégré à la structure - Hêtre teinté vernis à l'eau	Water-based stained varnished beech
FINITIONS TAPISSIER	UPHOLSTERED FINISHES
Tissu tendu, couture simple	Stretched fabric and single needle stitching
SPÉCIFICITÉ	SPECIFICITY
Existe en 125cm de longueur FFRAMBA125	Available in 49,2" length FFRAMBA125

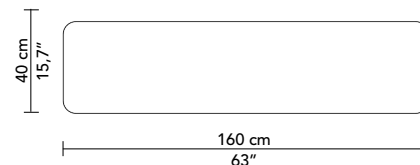
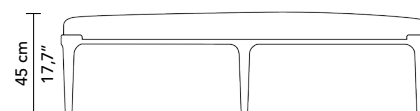
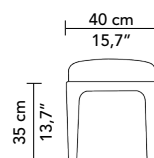

MÉTRAGE TISSU	FABRIC QUANTITY
- FFRAMBA125 : 1 m	- FFRAMBA125 : 1,1 yds
- FFRAMBA160 : 1,8 m	- FRAMBA160 : 2 yds

Poids : 15 kg

Weight : 33,06 lbs

Eco participation obligatoire pour une livraison en France : 1,8 € HT





