



MOBILIER
FURNITURE

VÉNUS

LINE

Sam Baron for Pierre Frey



Collection HÉRITAGE



VÉNUS by Sam Baron

Né en France, Sam Baron est diplômé de l'école des beaux arts de Saint Etienne et possède un post diplôme de l'école nationale des Arts Décoratifs de Paris.

Il ancre ses créations dans les recherches fonctionnelles et artistiques sans omettre les narrations culturelles et historiques. Son regard se positionne dans notre quotidien et la vie contemporaine au travers de relectures et réinterprétations de savoir-faire artisanaux ou industriels.

Il travaille comme designer pour plusieurs marques internationales : Dior Maison, Hennessy, Vista Alegre, La Redoute.. Pendant dix ans, il occupe la fonction de directeur créatif du département design de Fabrica, centre international de recherche en communication basé en Italie.

En 2009 il reçoit le grand prix de la création de la ville de Paris dans la section designer confirmé et est désigné en 2010 par Philippe Starck comme l'un des designers les plus importants de la décennie.

Born in France, Sam Baron is a graduate of the Saint Etienne School of Fine Arts and has a post-graduate degree from l'école nationale des Arts Décoratifs de Paris.

He anchors his creations in functional and artistic research without omitting cultural and historical narratives. His vision is positioned in our daily and contemporary life through rereadings and reinterpretations of artisanal or industrial know-how.

He works as a designer for several international brands: Dior Maison, Hennessy, Vista Alegre, La Redoute. For ten years, he was the creative director of the design department of Fabrica, an international research center in communication based in Italy.

In 2009 he received the Grand Prix de la Création de la Ville de Paris in the confirmed designer section and in 2010 he was named by Philippe Starck as one of the most important designers of the decade.

LE CONCEPT

La ligne VÉNUS, imaginée par Sam Baron, incarne un souffle nouveau dans l'univers du mobilier contemporain. Mariant habilement le classique et le moderne, son esthétique se distingue par une élégance affirmée. La corniche subtile ornant le piètement met en valeur la richesse et les nuances naturelles du bois.

Le plateau, disponible en finitions personnalisables, apporte une dimension précieuse à l'ensemble. Laques artistiques — Glacée, Kozo, Empreinte —, chêne gougé ou verre laqué offrent des variations raffinées qui créent un dialogue harmonieux entre textures et matières, sublimant le design d'une originalité rare.

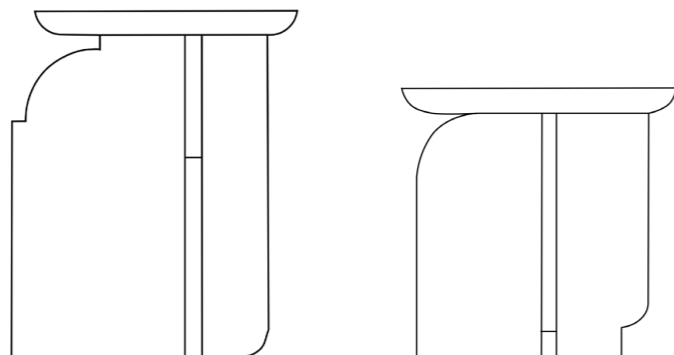

THE CONCEPT

The VÉNUS line, conceived by Sam Baron, introduces a fresh perspective to contemporary furniture design. Seamlessly merging classical and modern influences, its aesthetic is defined by a confident elegance. The subtle cornice adorning the base accentuates the wood's richness and natural nuances.

The tabletop, offered in customizable finishes, infuses the VÉNUS collection with sophistication. Artistic lacquers such as Glacée, Kozo, and Empreinte, gouged oak, or lacquered glass provide refined variations that foster a harmonious dialogue between textures and materials, elevating the design with a rare and distinctive originality.

VÉNUS

LINE



VÉNUS

Guéridon - Pedestal table - 39 cm / 15,3 inch

FVENUGU039 - Structure chêne, plateau verre laqué / Oak structure, lacquered glass top

FVENUGU039BI1 - Structure chêne, insert chêne gougé / Oak structure, gouged oak insert

FVENUGU039BI2 - Structure chêne, insert laque Glacée / Oak structure, Icy lacquer insert

FVENUGU039BI3 - Structure chêne, insert laque Kozo / Oak structure, Kozo lacquer insert

FVENUGU039BI4 - Structure chêne, insert laque Empreinte / Oak structure, Stamp lacquer insert



VÉNUS

Guéridon - Pedestal table - 42 cm / 16,5 inch

FVENUGU042 - Structure chêne, plateau verre laqué / Oak structure, lacquered glass top

FVENUGU042BI1 - Structure chêne, insert chêne gougé / Oak structure, gouged oak insert

FVENUGU042BI2 - Structure chêne, insert laque Glacée / Oak structure, Icy lacquer insert

FVENUGU042BI3 - Structure chêne, insert laque Kozo / Oak structure, Kozo lacquer insert

FVENUGU042BI4 - Structure chêne, insert laque Empreinte / Oak structure, Stamp lacquer insert





VÉNUS

by Sam Baron



Finition : Structure en teinte Blanchi sur chêne, vernis mat CO020M - Insert en Chêne gougé, Brun, vernis mat CO008GOM
 Finish: Structure in Bleached stain on oak, matt varnish CO020M - Insert in matt varnished Brown gouged oak CO008GOM

GUÉRIDON - PEDESTAL TABLE

REF: FVENUGU039B11

STRUCTURE	FRAME
Chêne massif	Solid oak
Assemblage : traditionnel	Construction: traditional

FINITIONS	FINISHES
Chêne teinté, vernis à l'eau, insert chêne gougé	Stained oak, water-based varnish, gouged oak insert

Existe avec inserts :		Available with inserts:	
- Laque Glacée	FVENUGU039B12	- Icy lacquer	FVENUGU039B12
- Laque Kozo	FVENUGU039B13	- Kozo lacquer	FVENUGU039B13
- Laque Empreinte	FVENUGU039B14	- Stamp lacquer	FVENUGU039B14

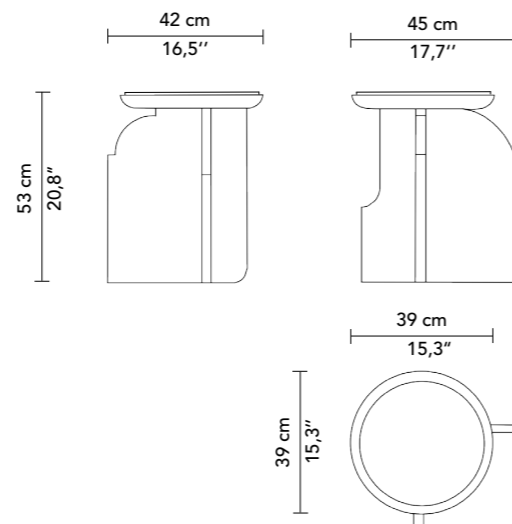

VÉNUS

by Sam Baron



Finition : Structure en teinte Blanchi sur chêne, vernis mat CO020M - Insert en laque Glacée, Graphite, vernis satiné LG002S
 Finish: Structure in Bleached stain on oak, matt varnish CO020M - Insert in satin varnished Graphite Icy Lacquer LG002S

GUÉRIDON - PEDESTAL TABLE

REF: FVENUGU039BI2

STRUCTURE		FRAME	
Chêne massif		Solid oak	
Assemblage : traditionnel		Construction: traditional	
FINITIONS		FINISHES	
Chêne teinté, vernis à l'eau, insert laque Glacée		Stained oak, water-based varnish, Icy lacquer insert	
Existe avec inserts :		Available with inserts:	
- Chêne gougé	FVENUGU039BI1	- Gouged oak	FVENUGU039BI1
- Laque Kozo	FVENUGU039BI3	- Kozo lacquer	FVENUGU039BI3
- Laque Empreinte	FVENUGU039BI4	- Stamp lacquer	FVENUGU039BI4

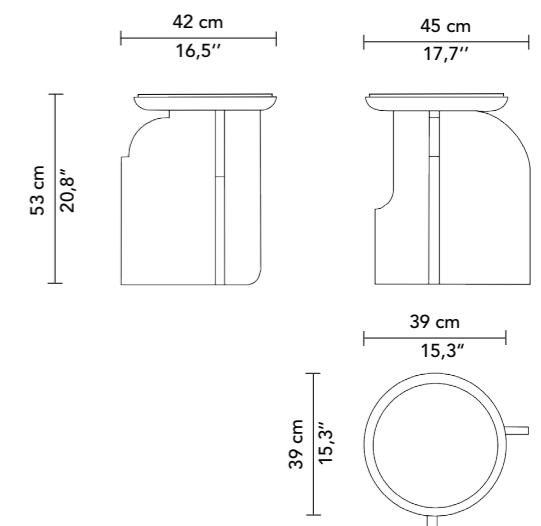

VÉNUS

by Sam Baron



Finition : Structure en teinte Blanchi sur chêne, vernis mat CO020M - Insert en laque Kozo, Safran, vernis brillant LK001B
 Finish: Structure in Bleached stain on oak, matt varnish CO020M - Insert in high gloss varnished Saffron Kozo lacquer LK001B

GUÉRIDON - PEDESTAL TABLE

REF: FVENUGU039BI3

STRUCTURE	FRAME
Chêne massif	Solid oak
Assemblage : traditionnel	Construction: traditional

FINITIONS	FINISHES
Chêne teinté, vernis à l'eau, insert laque Kozo	Stained oak, water-based varnish, Kozo lacquer insert

Existe avec inserts :		Available with inserts:	
- Chêne gougé	FVENUGU039BI1	- Gouged oak	FVENUGU039BI1
- Laque Glacée	FVENUGU039BI2	- Icy lacquer	FVENUGU039BI2
- Laque Empreinte	FVENUGU039BI4	- Stamp lacquer	FVENUGU039BI4

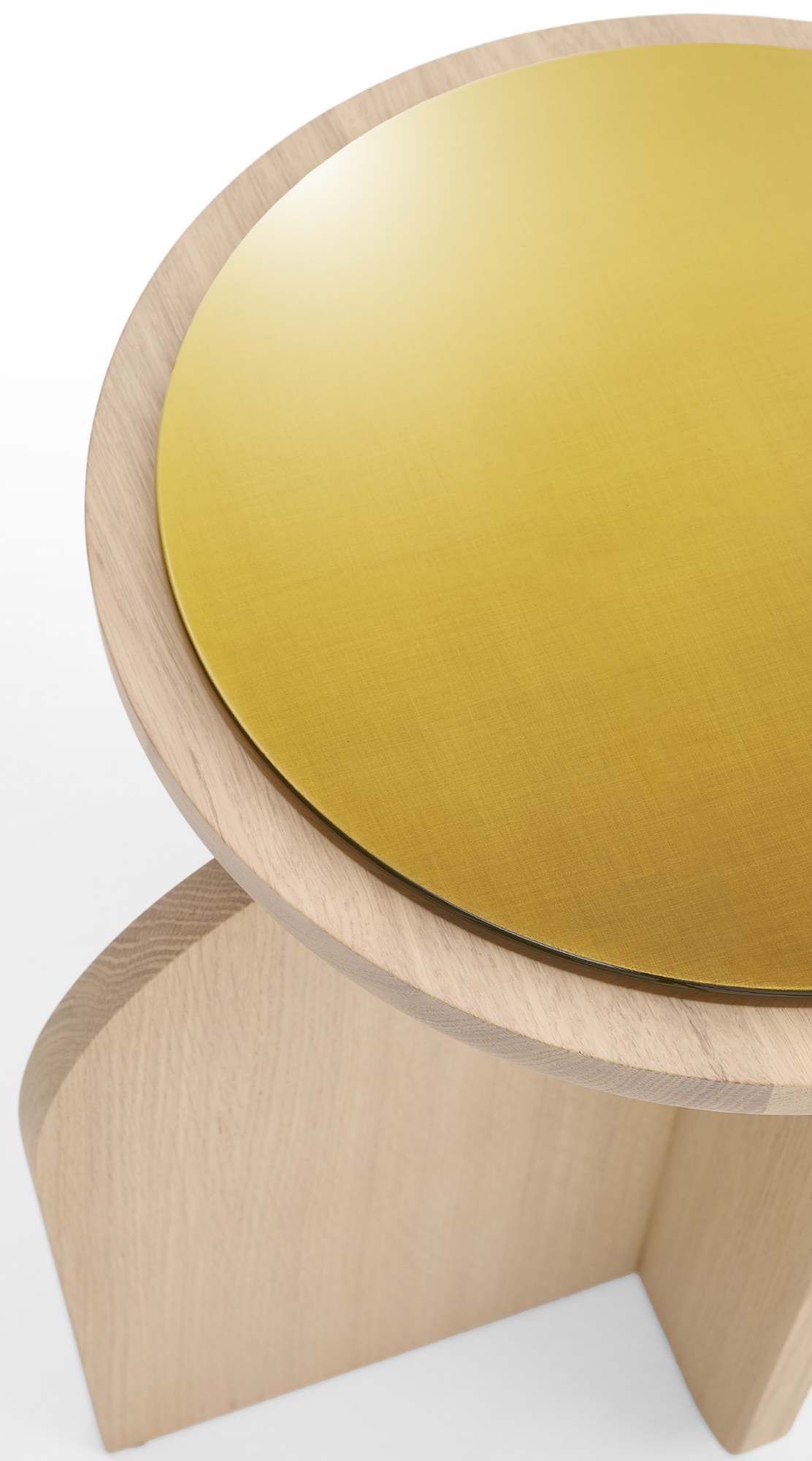
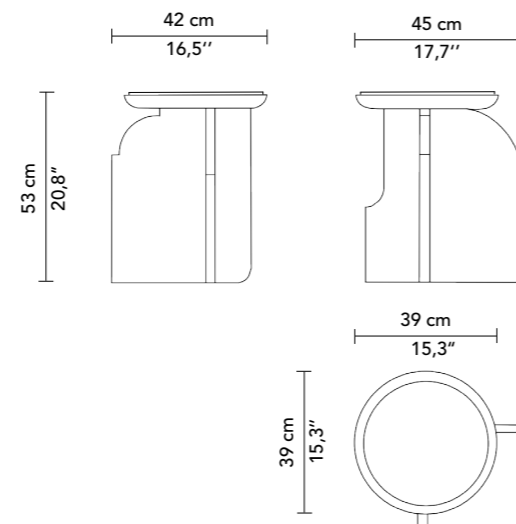

VÉNUS

by Sam Baron



Finition : Structure en teinte Châtaignier sur chêne, vernis mat CO004M - Plateau en verre laqué
Finish: Structure in Chestnut stain on oak, matt varnish CO004M - Top in lacquered glass

GUÉRIDON - PEDESTAL TABLE

REF: FVENUGU039

STRUCTURE	FRAME
Chêne massif Assemblage : traditionnel	Solid oak Construction: traditional
FINITIONS	FINISHES
Chêne teinté, vernis à l'eau, plateau en verre laqué	Stained oak, water-based varnish, lacquered glass top

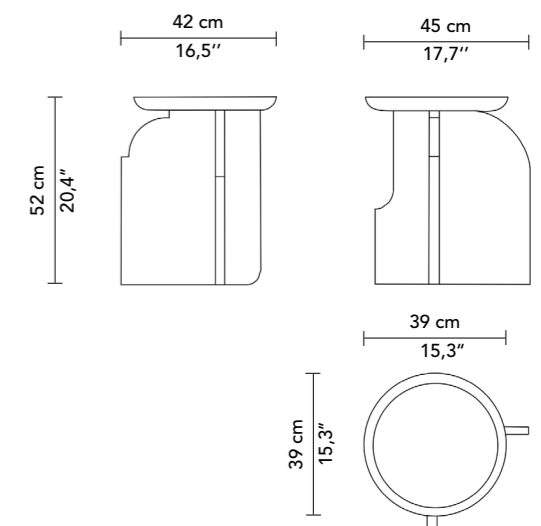

VÉNUMS

by Sam Baron



Finition : Structure en teinte Acajou sur chêne, vernis mat CO006M - Insert en Chêne gougé, Acajou, vernis mat CO006GOM
 Finish: Structure in Mahogany stain on oak, matt varnish CO006M - Insert in matt varnished Mahogany gouged oak CO006GOM



GUÉRIDON - PEDESTAL TABLE

REF: FVENUGU042BI1

STRUCTURE	FRAME
Chêne massif Assemblage : traditionnel	Solid oak Construction: traditional
FINITIONS	FINISHES
Chêne teinté, vernis à l'eau, insert chêne gougé	Stained oak, water-based varnish, gouged oak insert
Existe avec inserts :	Available with inserts:
- Laque Glacée FVENUGU042BI2	- Icy lacquer FVENUGU042BI2
- Laque Kozo FVENUGU042BI3	- Kozo lacquer FVENUGU042BI3
- Laque Empreinte FVENUGU042BI4	- Stamp lacquer FVENUGU042BI4

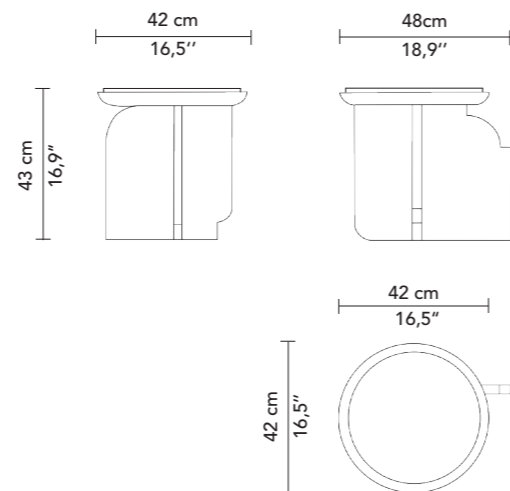



VÉNUS

by Sam Baron



Finition : Structure en teinte Acajou sur chêne, vernis mat CO006M - Insert en laque Empreinte, Terracotta, vernis brillant LE001B
 Finish: Structure in Mahogany stain on oak, matt varnish CO006M - Insert in high gloss varnished Terracotta Stamp lacquer LE001B

GUÉRIDON - PEDESTAL TABLE

REF: FVENUGU042BI4

STRUCTURE		FRAME	
Chêne massif		Solid oak	
Assemblage : traditionnel		Construction: traditional	
FINITIONS		FINISHES	
Chêne teinté, vernis à l'eau, insert laque Empreinte		Stained oak, water-based varnish, Stamp lacquer insert	
Existe avec inserts :		Available with inserts:	
- Chêne gougé	FVENUGU042BI1	- Gougé oak	FVENUGU042BI1
- Laque Glacée	FVENUGU042BI2	- Icy lacquer	FVENUGU042BI2
- Laque Kozo	FVENUGU042BI3	- Kozo lacquer	FVENUGU042BI3

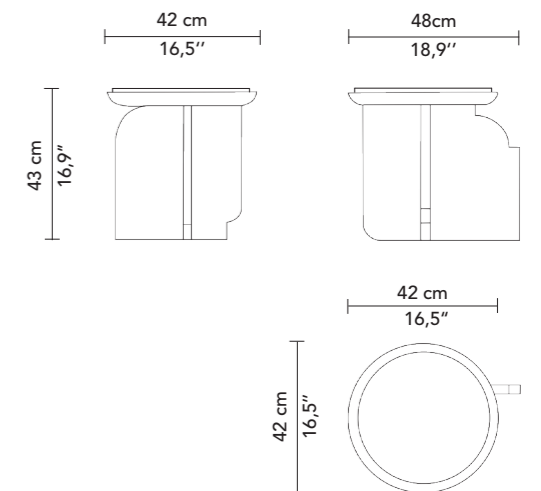

VÉNUS

by Sam Baron



Finition : Structure en teinte Châtaignier sur chêne, vernis mat CO004M - Plateau en verre laqué
 Finish: Structure in Chestnut stain on oak, matt varnish CO004M - Top in lacquered glass

GUÉRIDON - PEDESTAL TABLE

REF: FVENUGU042

STRUCTURE	FRAME
Chêne massif	Solid oak
Assemblage : traditionnel	Construction: traditional

FINITIONS	FINISHES
Chêne teinté, vernis à l'eau, plateau en verre laqué	Stained oak, water-based varnish, lacquered glass top

