

MOBILIER
FURNITURE

MILO

LINE

Guillaume Delvigne for Pierre Frey





© Baptiste Heller

MILO by Guillaume Delvigne

Designer diplômé en 2002 de l'École de Design Nantes Atlantique, Guillaume Delvigne débute entre Milan et Paris, auprès de grands noms comme George Sowden, cofondateur du mouvement Memphis, ou Marc Newson, star du design contemporain.

En 2011 il se lance en solo, inaugure sa première exposition personnelle à la ToolsGalerie et remporte le Grand Prix de la Création de la Ville de Paris. Aujourd'hui, il travaille avec des artisans, des éditeurs ou industriels, principalement dans le domaine du mobilier, de l'objet, et du luminaire. Il compte de nombreuses références, grandes Maisons françaises et étrangères ou jeunes éditeurs (Hermès, Frandsen, Hanoia, Lexon, La Chance, ENO studio, Hartô...).

Guillaume Delvigne est un dessinateur. Son travail, d'une grande sensibilité, est influencé par la photo, l'architecture et plus généralement, par tout ce qui est visuel. Il recherche l'équilibre parfait, sa patte est douce et épurée tout en étant extrêmement rigoureuse, son sens du détail très marqué.

A designer who graduated in 2002 from the Nantes Atlantique School of Design, Guillaume Delvigne began his career between Milan and Paris, working with big names such as George Sowden, co-founder of the Memphis movement, and Marc Newson, a star of contemporary design.

In 2011 he launches a solo show, inaugurates his first solo exhibition at the ToolsGalerie and wins the Grand Prix de la Création de la Ville de Paris. Today he works with craftsmens, publishers or industrialists mainly in the fields of furniture, objects and lighting. His clients are major French and foreign companies or younger publishers (Hermès, Frandsen, Hanoia, Lexon, La Chance, ENO studio, Hartô...).

Guillaume Delvigne is an illustrator. His highly sensitive work is influenced by photography, architecture and more generally by everything visual. He is looking for the perfect balance, his paw is soft and uncluttered while being extremely rigorous, his sense of detail is very strong.

LE CONCEPT

La ligne MILO, conçue par Guillaume Delvigne, se compose de tables basses et d'un guéridon, disponibles en essence de chêne et en laque.

Les plateaux des pièces semblent flotter au-dessus de leur pied central, créant une impression d'équilibre parfait tout en magnifiant les objets qu'ils exposent.

D'épaisseur généreuse, ils présentent des extrémités subtilement incurvées qui glissent vers le sol, rappelant le flux de l'eau. Cette pente douce et fluide confère à la ligne une allure organique et architecturale, ajoutant à la fois une sensation de mouvement délicat et un caractère visuel distinctif par le jeu de la lumière sur la matière.

Réalisée dans le respect d'un artisanat traditionnel en ébénisterie et en finition laquée, cette ligne met en lumière la beauté, la richesse des matériaux et s'intègre harmonieusement dans tous les décors.

THE CONCEPT

The MILO line, designed by Guillaume Delvigne, consists of coffee tables and a pedestal table, available in oak and lacquer.

The tabletops of these pieces appear to float above their central base, creating a sense of perfect balance while enhancing the objects they display.

With generous thickness, they feature subtly curved ends that gracefully glide towards the floor, reminiscent of water flow. This gentle and fluid curvature gives the line an organic and architectural look, adding both a feeling of delicate movement and distinctive visual character through the interplay of light on the material.

Crafted with respect for traditional woodworking and lacquering craftsmanship, this line highlights the beauty, the richness of the materials and seamlessly complements any decor.

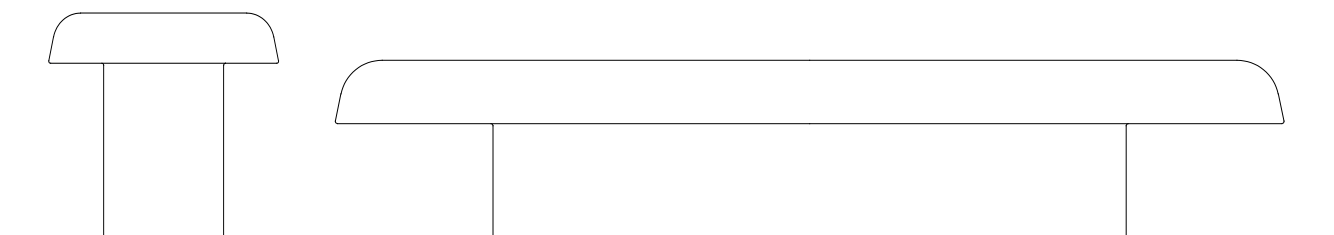

MILO

LINE



MILO

Table basse - Coffee table

FMILOTA140B - Chêne / Oak

FMILOTA140L - Laque mate / Mat lacquer

FMILOTA140LB - Laque grand brillant / High gloss lacquer

FMILOTA180B - Chêne / Oak

FMILOTA180L - Laque mate / Mat lacquer

FMILOTA180LB - Laque grand brillant / High gloss lacquer



MILO

Guéridon - Pedestal table

FMILOGU050B - Chêne / Oak

FMILOGU050L - Laque mate / Mat lacquer

FMILOGU050LB - Laque grand brillant / High gloss lacquer

























MILO

by Guillaume Delvigne



Finition / Finish : CHÊNE MAT CO103HSL

TABLE BASSE - COFFEE TABLE 140 CM

REF: FMILOTA140B

STRUCTURE	FRAME
Panneau bois	Wooden panel
FINITIONS	FINISHES
Existe en 3 options :	Available in 3 options:
- Chêne : FMILOTA140B	- Oak: FMILOTA140B
- Laque mate : FMILOTA140L	- Mat lacquer: FMILOTA140L
- Laque grand brillant : FMILOTA140LB	- High gloss lacquer: FMILOTA140LB
SPÉCIFICITÉ	SPECIFICITY
Taille sur mesure possible sur demande	Custom sizes available on request

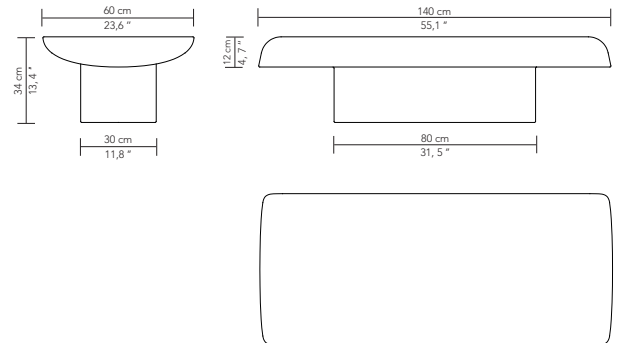
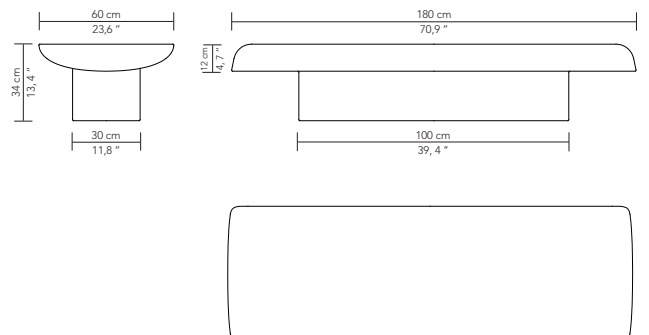

TABLE BASSE - COFFEE TABLE 180 CM

REF: FMILOTA180B

STRUCTURE	FRAME
Panneau bois	Wooden panel
FINITIONS	FINISHES
Existe en 3 options :	Available in 3 options:
- Chêne : FMILOTA180B	- Oak: FMILOTA180B
- Laque mate : FMILOTA180L	- Mat lacquer: FMILOTA180L
- Laque grand brillant : FMILOTA180LB	- High gloss lacquer: FMILOTA180LB
SPÉCIFICITÉ	SPECIFICITY
Taille sur mesure possible sur demande	Custom sizes available on request







MILO

by Guillaume Delvigne



Finition / Finish : LAQUE MATE RAL 070 50 55

GUÉRIDON - PEDESTAL TABLE

REF: FMILOGU050B

STRUCTURE	FRAME
Panneau bois	Wooden panel
FINITIONS	FINISHES
Existe en 3 options :	Available in 3 options:
- Chêne : FMILOGU050B	- Oak: FMILOGU050B
- Laque mate : FMILOGU050L	- Mat lacquer: FMILOGU050L
- Laque grand brillant : FMILOGU050LB	- High gloss lacquer: FMILOGU050LB
SPÉCIFICITÉ	SPECIFICITY
Taille unique en collection	One size in the collection

