



MOBILIER
FURNITURE

MAJORDOME

LIGNE / LINE

Sam Baron pour / for Pierre Frey





MAJORDOME Sam Baron

Né en France, Sam Baron est diplômé de l'école des beaux arts de Saint Etienne et possède un post diplôme de l'école nationale des Arts Décoratifs de Paris. Il ancre ses créations dans les recherches fonctionnelles et artistiques sans omettre les narrations culturelles et historiques. Son regard se positionne dans notre quotidien et la vie contemporaine au travers de relectures et réinterprétations de savoir-faire artisanaux ou industriels.

Il travaille comme designer pour plusieurs marques internationales : Dior Maison, Hennessy, Vista Alegre, La Redoute.. Pendant dix ans, il occupe la fonction de directeur créatif du département design de Fabrica , centre international de recherche en communication basé en Italie.

En 2009 il reçoit le grand prix de la création de la ville de Paris dans la section designer confirmé et est désigné en 2010 par Philippe Starck comme l'un des designers les plus importants de la décennie.

Born in France, Sam Baron is a graduate of the Saint Etienne School of Fine Arts and has a post-graduate degree from l'école nationale des Arts Décoratifs de Paris. He anchors his creations in functional and artistic research without omitting cultural and historical narratives. His vision is positioned in our daily and contemporary life through rereadings and reinterpretations of artisanal or industrial know-how.

He works as a designer for several international brands: Dior Maison, Hennessy, Vista Alegre, La Redoute. For ten years, he was the creative director of the design department of Fabrica, an international research center in communication based in Italy.

In 2009 he received the Grand Prix de la Création de la Ville de Paris in the confirmed designer section and in 2010 he was named by Philippe Starck as one of the most important designers of the decade.



LE CONCEPT

La collection Majordome s'inspire de l'époque des années 30. L'esprit décoratif français affectionnait particulièrement les pièces permettant de composer un salon nommé boudoir.

En hommage à Madeleine Castaing, antiquaire et décoratrice, le design de cette collection reprend et mélange de façon très contemporaine et avec une subtile élégance des détails de corniches classiques, des motifs animaliers et brillances de velours. Les différents éléments permettent de créer des ensembles s'adaptant à différentes typologies d'usages. La méridienne se complète de poufs et fauteuils pour créer des lieux propices aux conversations et rencontres entre amis.

THE CONCEPT

The Majordome collection is inspired by the 1930s. The French decorative spirit was particularly fond of pieces that could be used to create a living room called a boudoir.

In homage to Madeleine Castaing, antique dealer and decorator, the design of this collection includes classic cornice details, animal patterns and shiny velvet used in a very contemporary way and with a subtle elegance. The different elements allow to create sets that adapt to different types of uses. The meridian is complemented by footstools and armchairs to create places for conversations and meetings with friends.







FICHE TECHNIQUE / TECHNICAL SHEET



MAJORDOME Sam Baron pour / for Pierre Frey

MERDIENNE / CHAISE LOUNGE

REF: FMAJOME190

STRUCTURE	FRAME
Hêtre massif et panneaux de bois	Solid beech and wood panels
CONFORT	COMFORT
Ressorts Nosag	Zig zag spring
Dossier : Mousse polyuréthane 3 densités 40 kg/m ³ , 35 kg/m ³ et 26 Kg/m ³ parementée de ouate polyester.	Back: High resilience foam in 3 densities 40, 35 and 26 kg/m ³ covered with polyester wadding.
Assise : Mousse Haute Résilience 2 densités 35 kg/m ³ et 26 kg/m ³ parementée de ouate polyester.	Seat: High resilience foam in 2 densities 35 kg/m ³ and 26 kg/m ³ covered with polyester wadding.
PIETEMENT	LEG FINISHES
Socle laqué	Lacquered base
FINITIONS TAPISSIER	UPHOLSTERED FINISHES
Coutures simples	Simple seams
EN OPTION	OPTIONAL
2 Coussins en plumes d'oies	2 Goose feather cushions

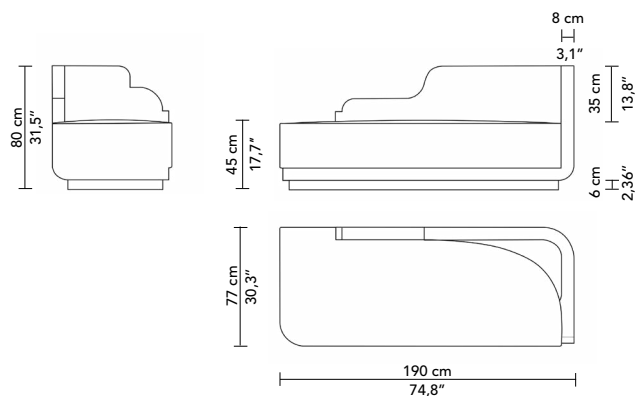

MT tissu* / Fabric qty* : 5,5 mt / 6 yds

* Métrage pour un tissu uni en laize 140cm / Quantity for a plain fabric in 55" width

MAJORDOME

Version optionnelle avec coussins

Optional version with cushions







FICHE TECHNIQUE / TECHNICAL SHEET



MAJORDOME Sam Baron pour / for Pierre Frey

FAUTEUIL / ARMCHAIR

REF: FMAJOFA070

STRUCTURE	FRAME
Hêtre massif et panneaux de bois	Solid beech and wood panels
CONFORT	COMFORT
Ressorts Nosag	Zig zag spring
Dossier : Mousse polyuréthane 2 densités 35 kg/m ³ et 26 kg/m ³ parementée de ouate polyester.	Back: High resilience foam in 2 densities 35 kg/m ³ and 26 kg/m ³ covered with polyester wadding.
Assise : Mousse Haute Résilience 3 densités 40 kg/m ³ , 35kg/m ³ et 26 kg/m ³ parementée de ouate polyester.	Seat: High resilience foam in 3 densities 40kg/m ³ , 35 kg/m ³ and 26 kg/m ³ covered with polyester wadding.
PIEITEMENT	LEG FINISHES
Socle laqué	Lacquered base
FINITIONS TAPISSIER	UPHOLSTERED FINISHES
Coutures simples	Simple seams

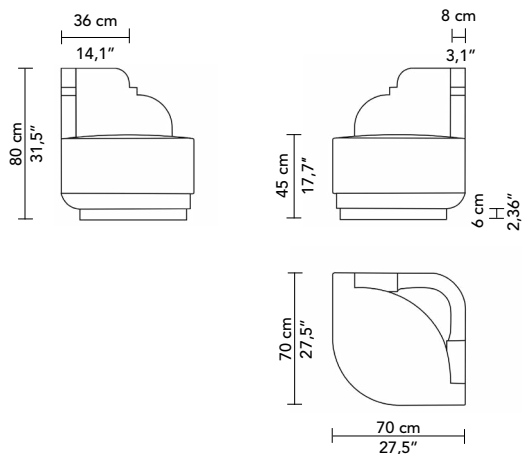

MT tissu* / Fabric qty* : 5,5 mt / 6 yds

* Métrage pour un tissu uni en laize 140cm / Quantity for a plain fabric in 55" width



FICHE TECHNIQUE / TECHNICAL SHEET



MAJORDOME Sam Baron pour / for Pierre Frey

POUF

REF: FMAJOPO160

STRUCTURE	FRAME
Hêtre massif et panneaux de bois	Solid beech and wood panels
CONFORT	COMFORT
Ressorts Nosag Assise : Mousse Haute Résilience 3 densités 40 kg/m ³ , 35kg/m ³ et 26 kg/m ³ parementée de ouate polyester.	Zig zag spring Seat: High resilience foam in 3 densities 40kg/m ³ , 35 kg/m ³ and 26 kg/m ³ covered with polyester wadding.
PIETEMENT	LEG FINISHES
Socle laqué	Lacquered base
FINITIONS TAPISSIER	UPHOLSTERED FINISHES
Coutures simples	Simple seams

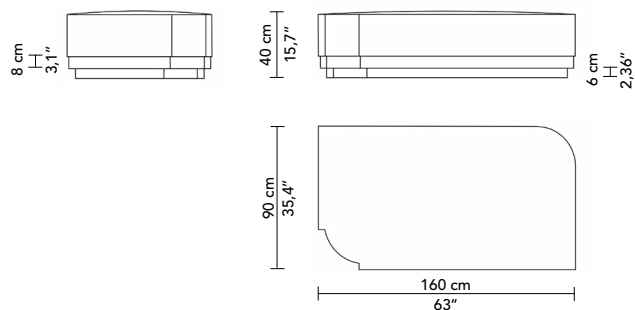

MT tissu* / Fabric qty* : 5 mt / 5,5 yds

* Métrage pour un tissu uni en laize 140cm / Quantity for a plain fabric in 55" width



FICHE TECHNIQUE / TECHNICAL SHEET



MAJORDOME Sam Baron pour / for Pierre Frey

POUF

REF: FMAJOPO040

STRUCTURE	FRAME
Hêtre massif et panneaux de bois	Solid beech and wood panels
CONFORT	COMFORT
Sangles élastiques Assise : Mousse Haute Résilience 2 densités 50 kg/m ³ et 25 kg/m ³ parementée de ouate polyester.	Elastic webbing Seat: High resilience foam in 2 densities 50kg/m ³ and 25 kg/m ³ covered with polyester wadding.
PIETEMENT	LEG FINISHES
Socle laqué	Lacquered base
FINITIONS TAPISSIER	UPHOLSTERED FINISHES
Coutures simples	Simple seams

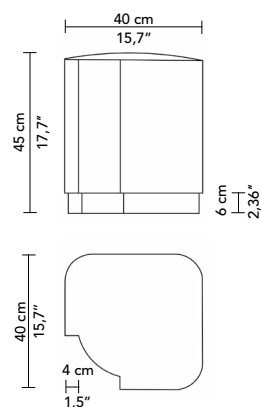

MT tissu* / Fabric qty* : 1,1 mt / 1,2 yds

* Métrage pour un tissu uni en laize 140cm / Quantity for a plain fabric in 55" width