



MOBILIER
FURNITURE

DUNE

LINE

Constance Guisset for Pierre Frey





@Felipe Ribon

DUNE by Constance GUISSET

En 2009 Constance Guisset fonde son studio spécialisé en design, architecture intérieure et scénographie. Ses objets tels que la suspension Vertigo, la lampe Cape ou encore le plat Canova font partie des icônes du design.

Elle explore également d'autres champs de recherche et d'expression comme la scénographie de spectacles vivants, d'expositions pour des musées ou des marques, la décoration d'intérieur et même l'édition de livres pour enfants. Le fil conducteur de toutes ces expériences est la recherche de l'équilibre entre l'incarnation du mouvement, la délicatesse et l'imaginaire tout en défendant une exigence de qualité, de confort et d'accueil des corps et de leurs gestes.

In 2009 Constance Guisset founded her studio specialized in design, interior architecture and scenography. Her objects such as the Vertigo suspension, the Cape lamp or the Canova dish are among the icons of design.

She also explores other fields of research and expression such as stage design for live shows, exhibitions for museums or brands, interior design and even the publishing of children's books. The common thread of all these experiences is the search for a balance between the embodiment of movement, delicacy and imagination, while defending a demand for quality, comfort and the welcoming of bodies and their gestures.

LE CONCEPT

DUNE est un tabouret de bar tripode tapissé. Son pied arrière en bois massif se plante dans le sol pour soulever légèrement le dossier. À la fois robuste et délicat, il propose un grand confort d'assise et d'usage, en épousant et soutenant avec sophistication le bas du dos.

THE CONCEPT

DUNE is an upholstered tripod bar stool. Its solid wood back leg is planted in the ground to slightly raise the backrest. Both sturdy and delicate, it offers great comfort in seating and use, with a sophisticated fit and support for the lower back.

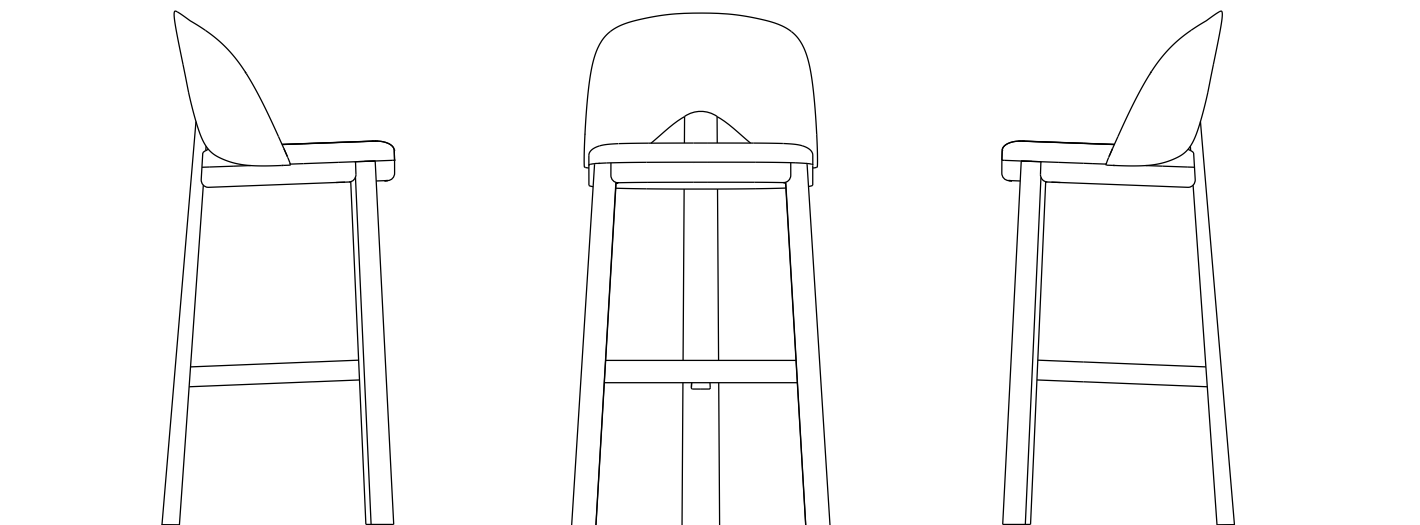

















DUNE

by Constance Guisset



Tissu / Fabric : MALOU Abeille F3291006
 Passepoil / Piping : MALOU Abeille F3291006
 Finition métal / Metal finish : Noyer d'amérique vernis mat HB105M, American walnut, matt varnish HB105M

TABOURET DE BAR - BAR STOOL

REF: FDUNETB052

STRUCTURE	FRAME
Hêtre ou Chêne massif	Solid beech or Oak
FINITIONS STRUCTURE	FRAME FINISHES
Hêtre teinté, vernis à l'eau 3 vernis possibles : mat, satiné, brillant	Beech stained, water based varnish 3 possible varnishes: matte, satin, gloss
FINITIONS TAPISSIER	UPHOLSTERED FINISHES
Tissu tendu et passepoil	Stretched fabric and piping
SPÉCIFICITÉ	SPECIFICITY
Structure en chêne disponible - sur demande MOQ : 12/ pièces FDUNETB052B2	Oak wood structure version available - on request MOQ : 12/ pieces FDUNETB052B2
MÉTRAGE TISSU	FABRIC QUANTITY
- FDUNETB052 : 1,5 m Métrage pour un tissu uni laize uni 140 cm	- FDUNETB052 : 1.5 yds Quantity for a plain fabric in 55" width

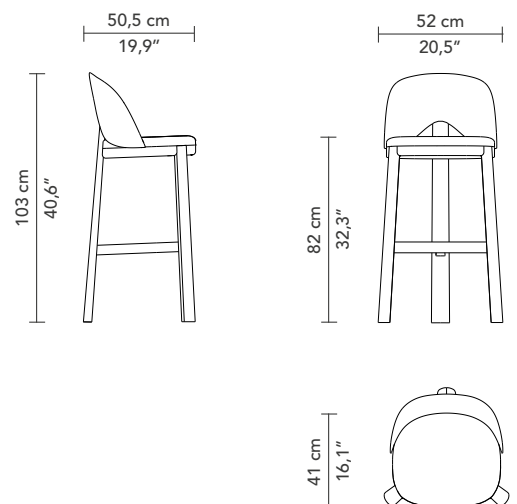

DUNE

by Constance Guisset



Tissu / Fabric : L5074_3021_3024_3143_I
 Passepoil / Piping : L5074_3021_3024_3143_I
 Finition métal / Metal finish : Noyer d'amérique vernis mat HB105M, American walnut, matt varnish HB105M

TABOURET DE COMPTOIR - COUNTER STOOL

REF: FDUN1TB052

STRUCTURE	FRAME
Hêtre ou Chêne massif	Solid beech or Oak
FINITIONS STRUCTURE	FRAME FINISHES
Hêtre teinté, vernis à l'eau 3 vernis possibles : mat, satiné, brillant	Beech stained, water based varnish 3 possible varnishes: matte, satin, gloss
FINITIONS TAPISSIER	UPHOLSTERED FINISHES
Tissu tendu et passepoil	Stretched fabric and piping
SPÉCIFICITÉ	SPECIFICITY
Structure en chêne disponible - sur demande MOQ : 12/ pièces FDUN1TB052B2	Oak wood structure version available - on request MOQ : 12/ pieces FDUN1TB052B2
MÉTRAGE TISSU	FABRIC QUANTITY
- FDUN1TB052 : 1,5 m Métrage pour un tissu uni laize uni 140 cm	- FDUN1TB052 : 1.5 yds Quantity for a plain fabric in 55" width

